

S U P P O R T E D B Y



Callide Oxyfuel Project – Lessons Learned

May 2014

Principal Author:

Dr Chris Spero
Callide Oxyfuel Project Director

Contributors:

Franco Montagner
Lyle Chapman
Doug Ranie
Toshihiko Yamada

Oxyfuel Technologies Pty Ltd
PO Box 2227
FORTITUDE VALLEY BC QLD 4006

Level 2, 540 Wickham St
Fortitude Valley QLD 4006

Copyright

Unless stated otherwise, copyright to this report is owned by Oxyfuel Technologies Pty Ltd (ACN 130 217 739) (“OTPL”) or used under licence.

Apart from fair dealings for the purpose of study, research, reporting, criticism or review as permitted under the *Copyright Act 1968* (Cth), no part may be reproduced by any process without the written permission of OTPL.

Disclaimer

No Reliance on this Report

This report was prepared by OTPL for the Global CCS Institute.

Third parties using or relying on information contained in this report do so at their own risk.

This document is published on the Global CCS Institute’s website in the interest of information exchange. The Global CCS Institute does not give any representation or warranty as to the reliability, accuracy or completeness of the information, nor does it accept any responsibility arising in any way (including by negligence) for errors in, or omissions from, the information.

No Liability

To the extent permitted by law, OTPL and its directors, officers, employees, agents, contractors, advisers and any other person associated with the preparation of this report:

- give no warranty, representation or guarantee as to the accuracy, completeness or reliability of the information contained in this report; and
- accept no responsibility for any loss, claim, damages, costs or expenses arising out of, or in connection with, the information contained in this report.

SUMMARY

The following report presents an overview of the Callide Oxyfuel Project (Stage 1 – Oxyfuel Combustion and CO₂ Capture) and describes in detail key technical aspects of the plant, project milestones, and lessons learned.

The Callide A facility located near Biloela in central Queensland comprises of 2 x 330 t/day air separation units, a 30 MWe oxy-fuel boiler and a 75 t/day CO₂ capture plant. The plant was commissioned in 2012 and as of March 2013 had achieved nominally 5500 hours of industrial operation in oxy-combustion mode and 2500 hours of industrial of the CO₂ capture plant.

The project has been able to demonstrate CO₂ capture rates from the Oxyfuel flue gas stream to the CO₂ capture plant in excess of 85%, and producing a high quality CO₂ product suitable for geological storage. In addition, other benefits observed from the oxy-firing and CO₂ capture demonstration have included: (i) increased boiler combustion efficiency; (ii) greater than 50% reduction in stack NO_x mass emission rates; and (iii) almost complete removal of all toxic gaseous emissions including SO_x, NO_x, particulates and trace elements from the flue gas stream in the CO₂ capture plant.

All phases of the Project have provided a great deal of knowledge and experience to inform future Oxyfuel technology development. Of particular importance have been the lessons learned concerning:

- Establishment of the Project (structure, business systems, budgets, and schedules)
- Contract management
- Communications (with Partners, Stakeholders and the public)
- Identification and control of technical risks associated with the technology
- Operating and maintenance strategies and experience
- Managing workplace health and safety and the environment
- Transitioning of the power station culture and skill base from conventional coal-fired power plant to more complex and multi-purpose facilities designed to make electricity and capture CO₂ and other emissions
- Enhancements that would be applied to the next scale up of the Oxyfuel and CO₂ capture technology
- Efficacy of the technology in general.

The Lessons Learned report is submitted to the Global CCS Institute as fulfilment of Activity 2 in accordance with the requirements of the GCCSI-OTPL Funding Agreement.

TABLE OF CONTENTS

SUMMARY	3
TABLE OF CONTENTS	4
1. INTRODUCTION.....	6
2. PROJECT OVERVIEW.....	7
2.1 General	7
2.2 Project Goals	7
2.3 Project Scope.....	8
2.3.1 Oxy-fuel demonstration	8
2.3.2 CO ₂ Transport and Geological Storage Assessment	8
2.3.3 Project Conclusion	8
2.4 Project Funders and Participants	9
2.5 Project Contracting and Construction	10
2.6 Technical Description – Oxyfuel Boiler.....	10
2.6.1 Oxyfuel Boiler General.....	10
2.6.2 Boiler and Mills	13
2.6.3 H ₂ O Remover and Air Heaters	14
2.6.4 Flue Gas Low Pressure Heater (FGLPH)	15
2.6.5 Gas Recirculation/Forced Draft and Induced Draft Fans.....	15
2.7 Technical Description - Air Separation Units (ASUs)	16
2.8 Technical Description - CO ₂ Purification Unit (CPU).....	16
2.9 Technical Description - CO ₂ Transport and Storage	17
3. PERMITTING	18
3.1 General	18
3.2 Air Separation Units	18
3.3 Boiler	18
3.4 CO ₂ Capture Plant.....	19
3.5 Overall Site	19
3.6 Environmental Outcomes.....	19
4. SAFETY & HAZARDOUS AREA ASSESSMENTS	20
4.1 General	20
4.2 Oxygen Safety.....	20
4.3 Hazardous Area Assessment	20
5. COMMISSIONING & OPERATIONAL EXPERIENCE	24
5.1 Air Separation Units	24
5.2 Oxyfuel Boiler	24
5.2.1 Commissioning Targets.....	24
5.2.2 Power Plant Safety System	25
5.2.3 Mode Change Results	25
5.2.4 Process Optimisation.....	25
5.2.5 Operational Outcomes	26
5.3 CO ₂ Capture Plant (CPU).....	33
5.3.1 CPU – Low Pressure (LP) Section	33
5.3.2 CPU – Four-Stage Centrifugal Compressor	34
5.3.3 CPU – High Pressure (HP) Scrubber	36
5.3.4 CPU – Condensate Streams	36
5.3.5 CPU – Dryers	37

5.3.6	CPU Coldbox	37
6.	REVIEW OF PROJECT MILESTONES AND OUTCOMES.....	39
6.1	General	39
6.2	Test campaigns.....	39
6.3	CO ₂ Storage.....	40
7.	COMMUNICATIONS	42
8.	CONCLUSION	43
9.	REFERENCES.....	45
10.	ACKNOWLEDGEMENT	46
	APPENDIX A - PROJECT AND CONTRACT MANAGEMENT STRUCTURE	47
	APPENDIX B - CALLIDE OXYFUEL PROJECT – PLANT PHOTOS	48
	APPENDIX C - SUMMARY OF CALLIDE OXYFUEL PROJECT MILESTONES	52

1. INTRODUCTION

The Callide Oxyfuel Project was launched in 2008 following commencement of the construction of Stage 1 at Callide A Power Station after a 2 year Front End Engineering Development (FEED) and Financial Investment Decision (FID) phase. Stage 1 consists of three main components - oxygen plant, and Oxyfuel boiler and a CO₂ capture plant.

Stage 2 of the project has provided assessments of options for storage of CO₂ product manufactured at the Callide A facility as well as options for a small scale trial of CO₂ injection in conjunction with others.

The Callide A facility commissioning dates were as follows:

Oxygen plant – January 2012

Oxyfuel boiler – May 2012

CO₂ capture plant – December 2012

The following report presents an overview of the Callide Oxyfuel Project (Stage 1 – Oxyfuel combustion and CO₂ Capture) and describes in detail key technical aspects of the plant, project milestones achieved, and lessons learned during the development, construction and operating phases to date.

2. PROJECT OVERVIEW

2.1 General

The idea of the Callide Oxyfuel Project was first conceived in late 2003 as an initiative of the Australian Coal Association COAL21 Program. The initial effort was to develop a plan for the development and implementation of Oxyfuel technology together with other low emission coal technologies. This came together with the publication in March 2004 of the COAL21 Low Emission Coal Roadmap.

In February 2004, a Working Group was established under the umbrella of COAL21, the CRC for Coal in Sustainable Development and the New Energy Development Organization (NEDO) in Japan to undertake a feasibility study on the Oxyfuel conversion of a 30 MWe coal fired boiler at Callide A and the addition of a CO₂ capture plant. The Study was completed in 2006, and an application made to the Commonwealth for funding under the Low Emission Technology Development Fund (LETDF).

The Project reached Financial Close in April 2008 with the execution of a LETDF Deed, execution of a Funding Agreement with COAL 21 through Australian Coal Association Low Emission Technology Ltd (ACALET), and establishment of an Unincorporated Joint Venture.

2.2 Project Goals

The project has two broad goals, namely to:

1. Demonstrate a complete and integrated process of oxy-fuel combustion of pulverised coal within a National Electricity Market facility, incorporating oxygen production, oxy-fuel combustion, and CO₂ processing and liquefaction; and to assess CO₂ transport and geological storage.
2. Obtain detailed engineering design and costing data and operational experience to underpin the commercial development and deployment of new and retrofit oxy-fuel boiler applications for electricity generation.

The 3 year demonstration project is being augmented by a research and development program to test different coals and operating conditions, so the plant has been built to allow for operational flexibility and includes the relevant field devices and software systems to facilitate such a program.

The Air Separation Units, Oxyfuel Boiler and CO₂ capture plant were commissioned in 2012; and the Research, Development and Demonstration phase (RD&D) commenced in December 2012 with an intention to operate until December 2014.

2.3 Project Scope

2.3.1 Oxy-fuel demonstration

The Oxyfuel demonstration scope has included the following elements:

- Refurbishment and retrofit of oxy-fuel technology to Callide A Unit No.4 (30 MWe)
- Installation of two (2) x 330 t/day Air Separation Units (ASUs)
- Installation of a 75 t/day CO₂ capture plant (CPU) treating a side stream of flue gas from the Oxyfuel boiler.

2.3.2 CO₂ Transport and Geological Storage Assessment

The project scope relating to CO₂ transport and geological storage has focussed on preliminary characterisation and assessment of the CO₂ storage potential of the Northern Denison Trough and Surat Basin. This work has consisted of 4 main activities to date:

- Collaboration with Origin and Santos to appraise depleted natural gas fields in the Northern Denison Trough (complete)
- Collaboration with ZeroGen to appraise saline aquifers in the Northern Denison Trough (complete)
- GCCSI funded studies on CO₂ storage site assessments, appraisal of Surat Basin storage potential, and review of Environmental and Social factors associated with CO₂ transport and geological storage(complete)
- Collaboration with CTSCo on the development of a CO₂ storage trial in the Surat Basin (complete).

The Project continues to consider opportunities to provide CO₂ for storage testing and possible industrial uses for Callide Oxyfuel CO₂ product.

2.3.3 Project Conclusion

The Project is scheduled to complete the demonstration program in December 2014. Wrap up activities will include final documentation of the Oxyfuel demonstration outcomes, sale of assets, and site closure. An important element of the Project has been international collaboration with an overarching goal of facilitating the commercialization of Oxyfuel technology. Of particular note has been the Project's involvement in the International Energy Agency Oxyfuel Combustion workshops and International Conferences; collaboration with the Vattenfall 30 MW_{thermal} Oxyfuel pilot facility at the Schwarze Pumpe Power Plant in Cottbus Germany; and more recently collaboration with the FutureGen 2.0 Project in the United States.

2.4 Project Funders and Participants

The overall structure of the project, including funders and participants is shown schematically in Figure 1. The structure represents an Unincorporated Joint Venture which is managed by a steering committee made up of one representative of each Participant (CS Energy Oxyfuel Pty Ltd, Glencore (formerly Xstrata), Carbon Storage Solutions (subsidiary of Schlumberger), IHI Oxyfuel Pty Ltd, JPower and Mitsui Oxyfuel Pty Ltd) plus one representative from ACA Low Emission Technology Ltd (ACALET). Oxyfuel Technologies Pty Ltd (OTPL) was established as an Agent for the unincorporated Joint Venture and has one director from the 6 Participant companies. The assets of the project, including Intellectual Property owned by the Joint Venture Participants (through OTPL) as tenants-in-common according to their respective shareholding.

Callide Oxyfuel Services Pty Ltd (COSPL) was set up as the project management company through which the daily affairs of the project (except funding) are handled. COSPL like OTPL has one director from the 6 Participant companies. All the contracts signed for the project have been executed through COSPL. The principal officers of OTPL and COSPL are the Project Director and Company Secretary.

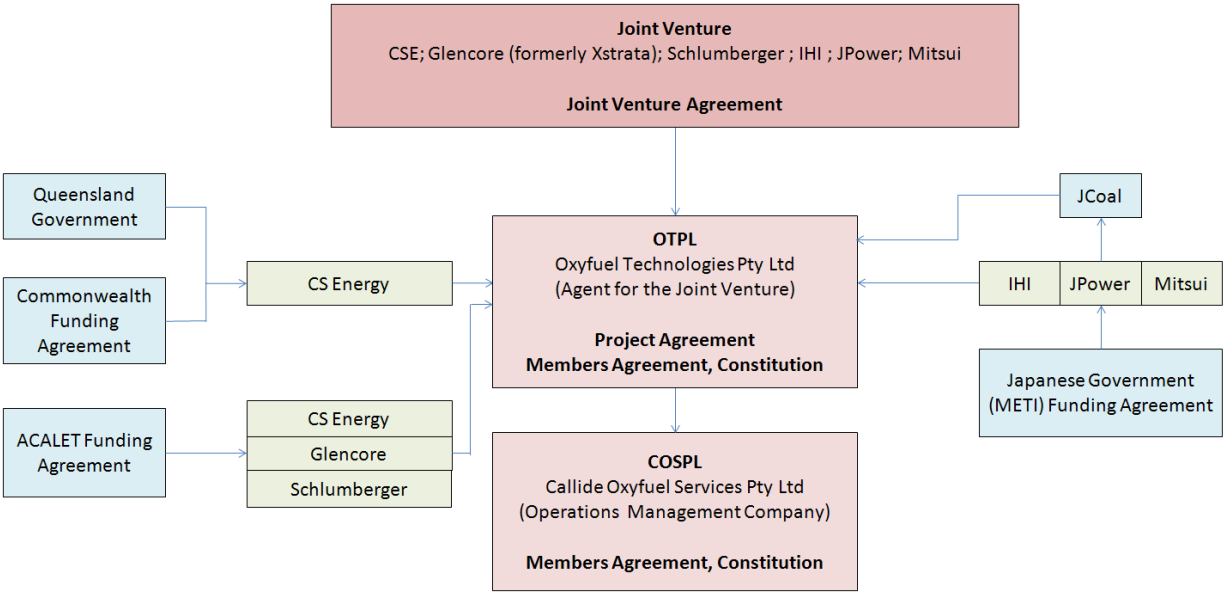

Figure 1 – Callide Oxyfuel Project Structure

The project budget is nominally \$240 million inclusive of all costs associated with the project to its end of life.

The structure shown in Figure 1 above was established to manage the commercial and legal risks associated with the Project. The structure has proved to be effective but at the same time has required a lot of management time and is expensive to maintain. The project funders (Commonwealth Government; Japanese Government through METI and JCoal; and ACALET) also have had their own specific requirements in order for each to manage its commercial and legal risks, and this is reflected in the structure above: i.e. between METI and the Japanese participants; between the Commonwealth Government and CS Energy; and between ACALET and the

Australian participants. The Queensland Government has supported the Project in two ways: by allowing CS Energy (as a Government Owned Corporation) to participate and make available the existing Callide A assets; and through a direct equity injection into CS Energy.

Overall, it may be noted that there is scope for a more practical project structure, to achieve the same end but without the commercial, legal and administrative complexity reflected in the existing structure.

2.5 Project Contracting and Construction

It was resolved during the FEED study in 2007/2008 that an Engineer Procure Construct Manage (EPCM) approach be adopted for the design, procurement and construction of the Project. The reason was that no single contractor was prepared to offer an overall EPC wrap because of the high risks associated with the first-of-a-kind nature of the project. Accordingly COSPL took on the EPCM role, registered with the Queensland Division of Workplace Health and Safety as the Principal Contractor, and established a small team to prepare the relevant documents such as the Construction Site Safety Management Plan, Construction Site Environmental Management Plan, and Document Management System. An Owner's Engineer was also appointed to assist COSPL in managing the numerous Design, Procurement and Construction Contracts.

The project implementation structure, including the main contracts awarded by COSPL for the design, procurement, and construction of plant, in various parts, is presented in Appendix A. In addition there were a large number of miscellaneous works contracts that were awarded and managed by COSPL.

2.6 Technical Description – Oxyfuel Boiler

2.6.1 Oxyfuel Boiler General

Oxyfuel combustion technology is one of a number of so called Low Emission Coal Technologies (LECTs) that are being developed on an international front for the main purpose of capturing CO₂. The Callide Oxyfuel Project is presently the largest operating oxyfuel power plant in the world and consists of 5 main process units, viz: two x 330 t/day cryogenic Air Separation Units (ASUs), Oxyfuel boiler (30 MWe generating capacity), flue gas low pressure pretreatment plant (100 t/day), flue gas high pressure treatment and CO₂ liquefaction plant (75 t/day), and CO₂ load-out tank and facilities.

Callide A Power Station comprises 4 x 30 MWe Units, with Riley Dodds Australia boilers and Parsons steam turbines. Unit 4 was commissioned in 1972, refurbished in 1998, and was chosen for the Oxyfuel conversion (retrofit) because it was in the best condition of the four units and close to the area to be developed for the ASUs and CPU. This size was considered sufficiently large to collect reliable data to support scale up to commercial units. Moreover, as a retrofit, it is considered to have a shorter lead-time and lower cost than a new plant, and therefore potentially a pathway to fast-track technology development.

From mid-2008 to January 2009, additional inspection and refurbishment work was undertaken and the unit returned to service in air-firing mode for several months to ensure the overall plant (especially turbine, boiler, and control and electrical systems) could be operated reliably and safely for at least 5 years. The oxy-combustion retrofit work commenced in October 2009 and

was completed in March 2011, and commissioning with Air started in April 2011. Oxy-firing was achieved in March 2012 and control system optimisation was carried out in April and May 2012.

The Callide Oxyfuel boiler has the following arrangement:

- There are 3 mills to pulverise the coal, of which 2 are required for normal full-load operation. Within the operating mills, under oxy-firing conditions, the coal is dried and transported by recycled flue gas that mainly consists of CO₂, H₂O and N₂.
- Callide-A boiler has 6 burners (2 per mill) and 4 burners are required for normal operation.
- There is a H₂O remover in the primary gas duct to remove SO₃ in order to protect the downstream parts of the process from corrosion, especially pulverized coal pipes. Bypass operation of H₂O remover can be selected as a demonstration test item.
- A Flue Gas Low Pressure Heater (FGLPH) is installed at the boiler outlet to reduce the temperature of the flue gas to around 145 °C prior to the Fabric Filter (FF), which has a service temperature limit of 180 °C. The cooling water used in the FGLPH is part of the boiler feedwater system. The FGLPH is bypassed during air-fired operation.
- O₂ from the ASUs is mixed with recycled flue gas after the Secondary Air Heater (SAH) and in addition a part of O₂ can be supplied to the burner flame area directly.
- Flue gas is recycled from the outlet of Induced Draft Fan (IDF) in oxyfuel operation by a Gas Recirculation Fan/Forced Draft Fan, and air is induced in air-firing operation by the same GRF.

New plant items for the boiler included: replacement of the middle row (2 burners) with IHI Low NO_x burners, two direct O₂ injection lances per burner (as a test item only), Flue Gas Low Pressure Heater (FGLPH), Induced Draft Fan (IDF), Gas Recirculation Fan/Forced Draft Fan (GRF), and H₂O remover (Figures 2 and 3).

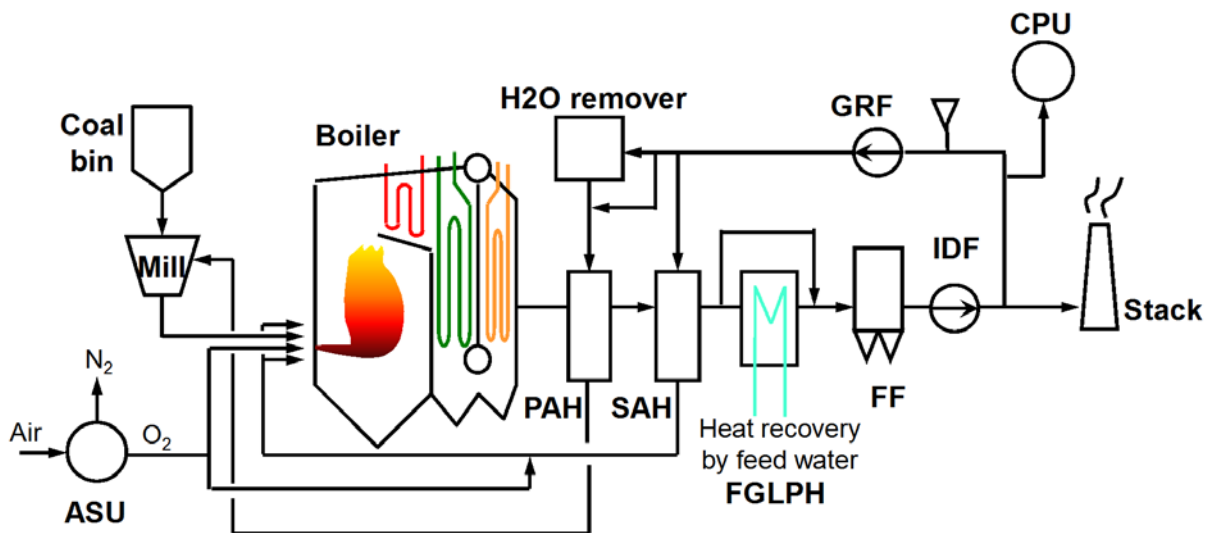

Figure 2 – Callide Oxyfuel Process (ASU – Air Separation Unit; PAH – Primary Air Heater; SAH – Secondary Air Heater; FGLPH – Flue Gas Low Pressure Heater; FF – Fabric Filter; IDF – Induced Draft Fan; CPU – CO₂ Purification Unit; GRF – Gas Recirculation Fan/Forced Draft Fan)



Figure 3 – View of Callide Oxyfuel Boiler equipment (A boiler house, B fabric filter, C flue gas exit duct, and D RFG duct)

An important differentiation between air-firing and oxy-firing is the composition of the flue gas (Figure 4). Since nitrogen is removed by the Air Separation Units, the CO₂ produced during combustion is concentrated into about ¼ of the volume of flue gas that would be present under air-firing conditions. This allows the CO₂ to be purified and separated from the other gases (primarily N₂, O₂ and Ar) using a cryogenic (physical process) rather than a chemical process.

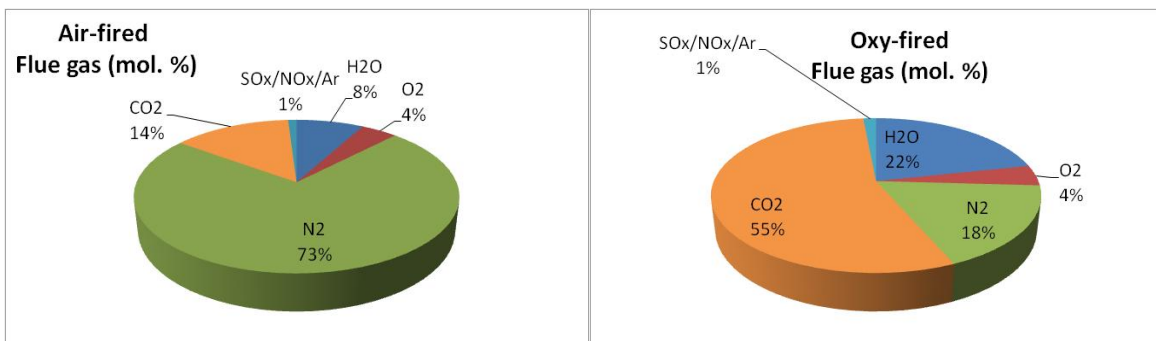

Figure 4 – (a) Typical flue gas composition under air-firing conditions; (b) Typical flue gas composition under oxy-firing conditions

General demonstration objectives are as follows:

- Assess performance of equipment items and identify any necessary modifications
- Determine thermodynamic performance of the complete plant
- Confirm that the plant can be operated in a safe and stable manner
- Assess how CPU responds to changes in flue gas composition
- Optimize the process control systems
- Assess corrosivity of the flue gas in the boiler and along the flue gas and RFG paths.

2.6.2 Boiler and Mills

The Callide A boilers were designed for Callide coal which is a sub-bituminous, medium calorific value, medium volatile, low sulfur coal. For the design of the Oxyfuel boiler, an 'average' and 'worst case' coal quality was specified together with the expected range for each quality parameter (Table 1). The coal is supplied from the adjacent Callide Coal Mine. As discussed in Section 6.2 of this report, the Callide A boiler has operated with Callide coal significantly outside the design range in terms of ash content and gross calorific value.

The boiler supplies 135 t/h of steam at 460°C and 43 bar. There are six front-wall burners arranged in three rows of two, each row served by its own mill: top row C1 and C2 Riley Dodds Flare Type Burners; middle row A1 and A2 IHI Low NO_x Burners; and bottom row B1 and B2 Riley Dodds Flare Type Burners. Coal composition data are presented in Table 1.

The boiler is designed to achieve full load on air and oxygen. Under oxy-firing conditions, the O₂ is injected into the Recycled Flue Gas (RFG) stream just downstream of the Secondary Air Heater. The total amount of oxygen introduced to the boiler is the same in oxy-mode as in air mode and in the former case consists of two portions: O₂ that is already in the RFG stream as well as the additional (and majority of the O₂ that is introduced into the Secondary Gas Stream. In addition, there are two O₂ lances on each burner for additional O₂ staging if required. The operational intent in oxy-firing mode is to achieve furnace heat absorption similar to that under air-firing conditions. In air-firing mode, the overall O₂ concentration at the boiler inlet (primary air plus secondary air) is 21 vol.%. Under oxy-firing conditions, the overall O₂ concentration at the boiler inlet (primary gas plus secondary gas) is maintained by selection within the range of 24 vol. % to 30 vol. %. The change from air- to oxy-firing (and vice versa) is made at 80% load or above and is completed within 90 minutes under full automatic control. Typical flue gas composition at the boiler exit for full load from air-firing to oxy-firing is considered in Section 5 of this report.

In air-fired mode, as with all boilers, the flue gas oxygen content is controlled by adjusting the air flow to ensure that there is adequate excess air for complete combustion. In oxy-firing mode, the flue gas oxygen content is controlled by adjusting the amount of oxygen injected into the secondary gas stream and at the same time regulating RFG flow to maintain the boiler inlet O₂ set point referred to in the paragraph above. As opposed to the boiler inlet O₂ set points, the boiler exit O₂ set points are the same for air-firing and oxy-firing, increasing from 2.7 vol.% wet at 100% load factor (30 MWe) up to 5.6 vol.% wet at minimum load.

Development Objectives are as follows:

- Assess effect of RFG on mill performance
- Achieve burner stability with and without oxygen lance in service
- Adjust boiler heat flux to achieve required steam flow rate and quality
- Establish how slagging and fouling are affected and how they are managed.

Table 1 - Callide Oxyfuel Project Design Coal Specification

Property ¹	Unit ²	Value		Range
		Design coal	Worst coal ³	
Total moisture	%, ar	14.4	14.0	12 – 16
Ash	%, ar	21.0	23.5	19 – 24
Volatile matter	%, ar	22.1	21.38	-
Fixed carbon	%, ar	42.5	41.1	-
Gross calorific value	MJ/kg	19.34	18.19	-
Total sulfur	%, ar	0.16	0.21	0.1 – 0.3
HGI		80		70 - 95
Nominal topsize	mm	90		70 – 100
Fines (< 3 mm)	%	35		30 – 45
Ultimate analysis				
Carbon	%, daf	78.1	78.0	77.0 – 80.0
Hydrogen	%, daf	4.10	3.96	3.7 – 4.30
Nitrogen	%, daf	1.12	1.10	0.95 – 1.2
Sulfur	%, daf	0.24	0.34	0.2 – 0.5
Oxygen	%, daf	16.42	16.62	14.0 – 18.0
Ash Analysis				
SiO ₂	%	49.8		35 – 60
Al ₂ O ₃	%	30.2		20 – 35
Fe ₂ O ₃	%	13.2		5 – 25
CaO	%	1.3		0.5 – 7.0
MgO	%	0.9		0.4 – 2.0
Na ₂ O	%	0.1		0.05 – 0.5
K ₂ O	%	0.2		0.05 – 0.8
TiO ₂		1.9		1.5 – 2.5
Mn ₃ O ₄		0.3		0.1 – 0.4
P ₂ O ₅	%	0.2		0.04 – 2.5
SO ₃	%	1.4		0.5 – 3.0
Ash fusibility temperatures				
		Reducing atmosphere		
Deformation	°C	1200		1150 – 1400
Sphere	°C	1300		1300 – 1500
Hemisphere	°C	1350		1350 – 1550
Flow	°C	1400		1400 - 1600

Notes:

1. Properties and units as defined in AS 1038
2. ar – as-received; daf – dry, ash-free
3. Worst coal – this is notional and was used for plant sizing in the design phase

2.6.3 H₂O Remover and Air Heaters

As indicated in Figure 2, the RFG is split into two streams (Primary-RFG and Secondary-RFG) which substitute for Primary Air and Secondary Air in air-firing mode. Initially, the Primary-RFG is cooled directly using process water in the H₂O remover vessels to lower the moisture content (new

equipment) to around 8 vol. % and remove SO₃ from the flue gas. This cooler is always bypassed in air-mode and can be bypassed in oxy-mode. The cooled PRFG then enters the primary gas/air heater (new equipment), a tubular design, and is heated to 350°C.

The Secondary-RFG is heated in the secondary air heater (existing equipment) to 280°C. Oxygen is mixed with the heated Secondary-RFG and passed to the windbox and through adjustable air/gas registers around the burners to support combustion of the coal that is entering with the Primary-RFG. For safety and practical reasons, no oxygen is fed with the Primary-RFG.

Development Objectives are as follows:

- Determine low-temperature corrosion rates in air heaters
- Determine acid corrosion rate in flue gas cooler and Primary-RFG ductwork downstream to the mills.

2.6.4 Flue Gas Low Pressure Heater (FGLPH)

Although the oxyfuel boiler was designed to achieve a similar heat flux to air firing, the flue gas temperature exiting the boiler is higher because the air side of the Secondary Air Heater (usually at 30 °C) is now at 150°C in oxy-combustion mode and requires a flue gas cooler (new equipment) to protect the existing fabric filter (baghouse). For oxy-firing, the temperature of the flue gas exiting the secondary air heater is 250°C and the cooler reduces this to 150°C. Feedwater is used for cooling and the heat added increases generating efficiency by reducing the steam extraction to heat the boiler feed water. When air firing the flue gas cooler can be bypassed as the flue gas is at the required temperature of 150°C.

Development Objectives are as follows:

- Determine low-temperature corrosion rates.

2.6.5 Gas Recirculation/Forced Draft and Induced Draft Fans

The original Forced Draft (FD) and Induced Draft (ID) fans were replaced as part of the Oxyfuel retrofit to allow for the additional pressure required for the flue gas recirculation system and in the case of the FD fan the higher temperature of the RFG compared to normal intake air temperature (Table 2). In addition to the new fans, the control systems were also modified to achieve closer control of flows rates, which is especially important during the air-to-oxygen and oxygen-to-air transitions.

Table 2 – Performance of old and new fans

Parameter	GR/FD Fan		ID Fan	
	Original	New	Original	New
Number of Fans	2 x 50%	1 x 100%	2 x 50%	1 x 100%
Power (kW)	97	420	179 each	530
Flow (m ³ /min)	1340 (each)	2380	1950 (each)	4220
Speed (rpm)	985	1485	980	1485
Pressure (kPa absolute)	3.3	7.6	3.9	5.5
Service Temperature (°C)	40	150	149	150

2.7 Technical Description - Air Separation Units (ASUs)

The ASU consists of 2 x 330 t/day trains delivering 98% pure oxygen at 1.8 bar(A). The ASUs are of a standard design and can turn down to 80% of full load. Oxygen production rates can be modulated (to an extent) to match boiler consumption rates. Each train is fitted with safety shutdown skids to isolate the ASUs from the boiler.

Development Objectives are as follows:

- Achieve integrated operation of ASU with boiler.

2.8 Technical Description - CO₂ Purification Unit (CPU)

The cryogenic CPU is designed to deliver a net production of CO₂ of 75 t/day of 99.9% pure CO₂ at 16.2 bar(A) and -30°C for transportation in road tankers (Figure 5). The actual CPU production rate is nominally 100 t/day but approximately 25% of the CO₂ product is recycled and utilised within the process, especially the Coldbox, to effect the separation of inert gases and purification of the CO₂ product.

In common with all Australian coal-fired boilers, there is no Selective Catalytic Reduction for NO_x control or Flue Gas Desulfurization. Hence, upstream of the CPU, the flue gas is cooled and neutralized in a Low Pressure scrubbing column with a caustic soda/water wash that removes the SO₂, HCL, HF, and NO₂. The exiting flue gas is blown through a fabric filter and screen filter to remove any carry over particulates and then enters an Atlas Copco four-stage centrifugal compressor with inter- and after-coolers. The coolers condense additional gaseous contaminants (such NO₂ from converted NO) and the acidic water formed also removes the majority of the Hg (refer to Section 5.3.2). The flue gas is then further cooled and washed with chilled-water in a High Pressure column and then dried in pressure-swing absorption columns that use recycled non-condensable gases (N₂, O₂ and Ar) separated from the carbon dioxide upstream in the cryogenic stage for regeneration. The final CO₂ separation involves a cryogenic plant with an Ammonia Refrigeration circuit and recycled CO₂ to achieve liquefaction of near-pure CO₂ product.

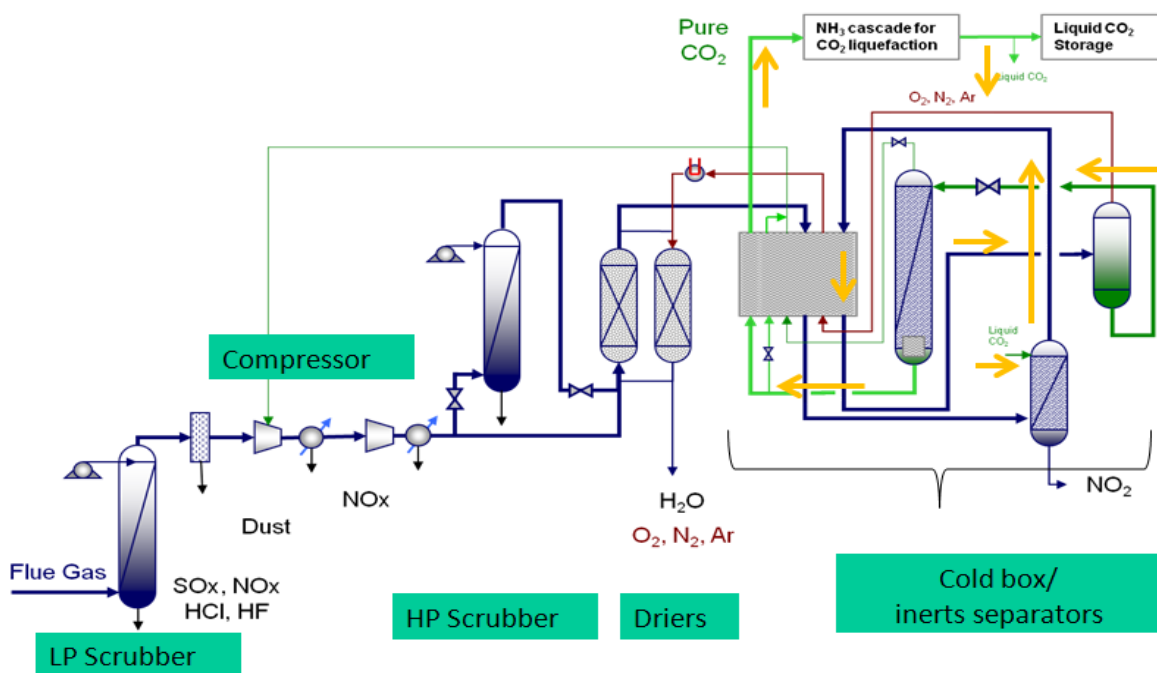

Figure 5 – Schematic of Callide A CO₂ Capture Plant (Courtesy Air Liquide)

Development Objectives are as follows:

- Achieve integrated operation of CPU with boiler
- Determine how CO₂ capture efficiency and purity vary with flue gas composition.

2.9 Technical Description - CO₂ Transport and Storage

One of the objectives of the Callide Oxyfuel Project is to facilitate the testing or demonstration of CO₂ geological storage. The Queensland Government Carbon Geo-storage Initiative has undertaken a mapping of potential CO₂ storage reservoirs in Queensland, published in 2009. From this work, Bradshaw et al (2010) have ranked the prospectivity of various geological basins in Queensland and estimated CO₂ storage potential of the 'high-prospectivity' areas to be in excess of 50 billion tonnes (Figure 6).

With support from the GCCSI, the Callide Oxyfuel Project has undertaken an initial appraisal and assessment of a number of CO₂ storage options in the Surat basin including road transportation of CO₂ from Callide A (Spero et al 2013a, b).

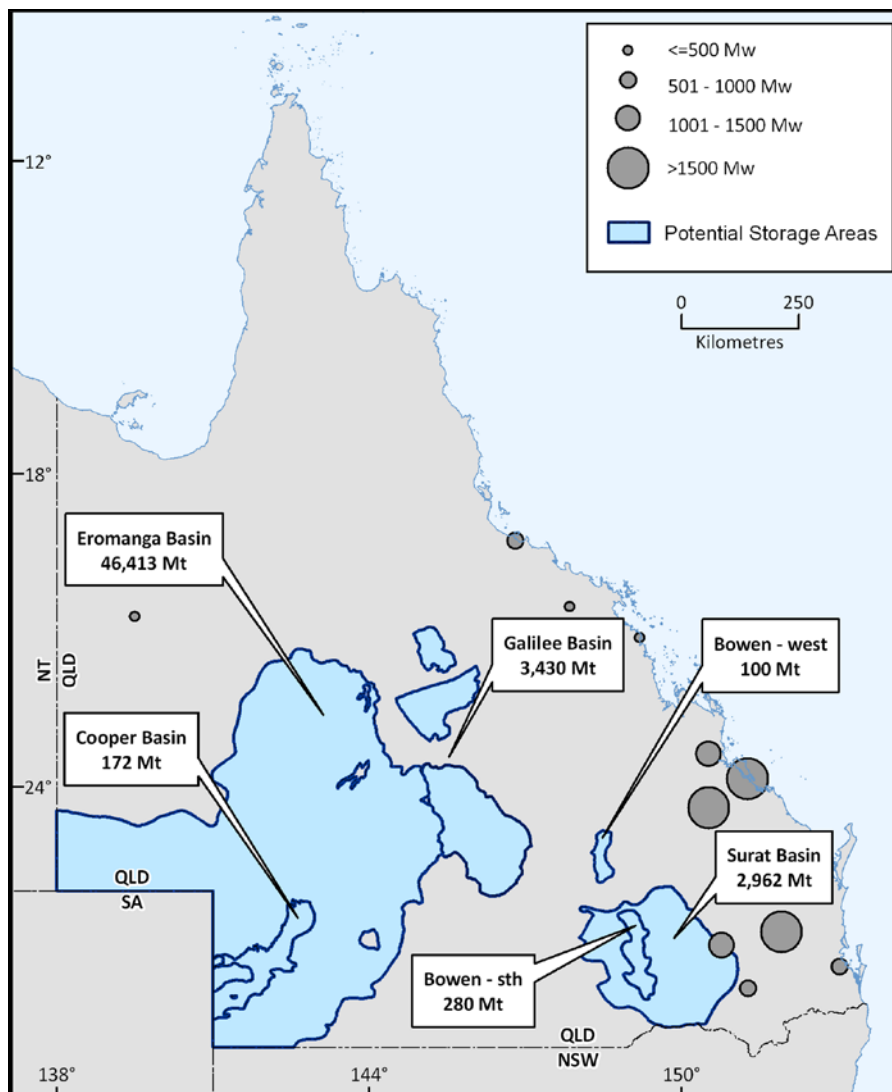

Figure 6 – Maximum potential CO₂ Storage for high prospectivity areas in Queensland (Bradshaw et al, 2010)

3. PERMITTING

3.1 General

The permitting of the Callide Oxyfuel Project was done as an extension to the existing Callide A Developmental Approval through the Queensland Department of Environmental and Heritage Protection (DEHP). It was determined that the additions made did not materially affect the scale or the primary purpose of the facility (being the production of electricity). During the developmental phase and the construction phase, the Project remained active in consulting with key stakeholders including Government (Queensland and Commonwealth) and the public through formal meetings, publications and media releases, and open days.

3.2 Air Separation Units

Because of the nature of the waste products from the ASU, principally Nitrogen, no additional licence limits were deemed necessary by the DEHP, however a large number of release points (including the main outlet of waste nitrogen, vent valves on the oxygen control skid and pressure safety valves) were registered with specific coordinates and heights.

3.3 Boiler

The final licensing arrangements for the boiler to cover operations under oxy-firing conditions was developed consultatively with the DEHP and consisted of the following key conditions.

Table 3 – Callide Oxyfuel Boiler Environmental Licence Conditions for Emissions to Air

Parameter	Air-firing	Oxy-firing	Comment
Coal Sulfur	No change Coal Sulfur \leq 0.35 mass % as-received (monthly average)		This was established after a series of combustion calculations and air dispersion modelling.
Particulates	No change. Particulates \leq 100 mg/Nm ³ @ 12% CO ₂) on 4 hour moving average (80% of a given month) – 1 registered release point (CA2 – Stack)		Testing has indicated that the normalised particulate emissions under oxy-firing conditions are slightly lower than under air-firing conditions. This is primarily because part of the flue gas stream which is recycled passed through a wet scrubber (H ₂ O Remover) and part of the flue gas stream goes to the CPU where all the particulates are removed by wet scrubbing and filters.
NOx	NOx to be monitored continuously \leq 850 ppmv (normalised to 7% O ₂) – 1 registered release point (CA2 – Stack)	NOx to be monitored continuously. \leq 70 g/s (1 hour moving average) as measured by CEMS on the stack inlet/flue gas recirculation line	There are numerous registered release points on the CPU, but there is a main-vent that releases above the height of the CPU Coldbox and carries primarily waste gases from regeneration of the driers.

3.4 CO₂ Capture Plant

For the CO₂ capture plant there is one major release point for normal operation which is positioned above the CPU Coldbox. Other vents exist for start-up and emergency discharge. NO_x is limited to 70 g/s (1 hour moving average) as a reference level measured at the stack inlet.

3.5 Overall Site

For the overall site:

- Limits on runoff, stormwater and seepage: pH 6.5 – 9.0; Dissolved O₂ > 2 mg/L; Suspended Solids ≤ 100 mg/L; Total dissolved solids ≤ 1450 mg/L; Chloride (Cl) ≤ 400 mg/L.
- Process waters from the Boiler and CPU are treated on site and discharged with ash to the ash dam.
- Noise modelling was conducted prior to finalisation of the design of the Boiler and CPU taking into consideration all local residences. Modelling indicated that Noise targets would not be exceeded (since verified). However, to meet Workplace Health and Safety noise standards acoustic enclosures were constructed around the 2 ASU air compressors and the flue gas compressor.

3.6 Environmental Outcomes

To date the Callide Oxyfuel plant has been able to successfully and dutifully manage its environmental obligations which are a key performance parameter for the Project.

In the consideration of future Oxyfuel plant, further attention could be given to rationalisation of the number of gas vents especially around the CO₂ capture plant, the option of processing and recovering potable water from waste water streams, and beneficial use of other waste streams such as vented N₂ and Ar gases, and Nitric Acid that is condensed in the inter-cooler and after-cooler on the flue gas compressor (refer to Sections 5.3.2).

4. SAFETY & HAZARDOUS AREA ASSESSMENTS

4.1 General

A key aspect to the commissioning and operation of the Callide Oxyfuel Project has been the identification, assessment and management of potential new workplace Health and Safety hazards associated with operation of the boiler under oxy-firing conditions and capture of the CO₂.

During the design phase, a series of Hazard and Operability Studies (HAZOPs) were conducted on each major section of plant and on the combined (overall) system by teams comprised of representatives from the Original Equipment Manufacturers or Vendors, the Operator, the Owner and a HAZOP Methodology expert. The outcome of the HAZOP Studies were a refinement in the physical design of the plant, especially around plant interfaces, and specific Safety Integrity levels for Safety Instrumented Systems and Emergency Stops that were designed into the system. Of particular relevance to the HAZOP studies were the Process Flow Diagrams (PFDs), Piping/Process and Instrument Diagrams (P&IDs), and International Standards IEC 61508 and 61511 which guide and prescribe methodology and requirements for Safety Integrity Levels (redundancy) of all safety loops in the plant control systems.

Prior to hot commissioning of plant, there were a number of sign-offs required, not least of which is acknowledgement that actions arising out of HAZOP studies for the plant in question have been completed and appropriate action implemented.

Another phase of the Workplace Health and Safety consideration at site has been the identification and assessment of hazardous areas and the identification and implementation of controls necessary to manage those hazards.

4.2 Oxygen Safety

One of the key learnings from the Callide Oxyfuel Project has been the safe industrial use of Oxygen which is an essential component of Oxyfuel technology. On the one hand Oxygen is essential for life, but it is also a powerful oxidant and requires special treatment when the level exceeds about 23 vol. %. Many materials that will not burn in air will do so in an oxygen-enriched atmosphere and will have lower ignition energies and burn more rapidly. Oxygen is reactive at ambient conditions, and its reactivity increases with increasing pressure, temperature and concentration.

As a consequence of the hazards associated with oxygen-enriched atmospheres, careful attention has been given to the selection of materials and the cleanliness of these materials when in oxygen service. A detailed description of the hazards and measures required to control these hazard are published in a number of Codes such as the ASTM Safe Use of Oxygen and Oxygen Systems: Handbook for Design, Operation, and Maintenance (2009).

4.3 Hazardous Area Assessment

A hazardous area is one in which a toxic or flammable gas atmosphere is or may be expected to be present in quantities such as to require special precautions.

Potential hazards that have been identified and assessed for the Callide Oxyfuel Project are as follows:

Air Separation Units

- Uncontrolled release of N₂ (a potential asphyxiate) stripped from the air during the air separation process.
- Uncontrolled release of Oxygen (oxidizing agent) as the main product from the process.
- Uncontrolled release of Hydrogen (used in small quantities) as a fuel within O₂ product Hydrocarbon analysers used to detect dangerous levels of CH₄ and other Hydrocarbons (HCs) absorbed from the air by liquid O₂ during the Oxygen separation and liquefaction process steps.

Oxyfuel Boiler

- Coal dust clouds exceeding 50 mg/Nm³ (applies to air and oxy-firing)
- Uncontrolled release of flue gas (from the slightly pressurised section of duct work, Secondary Gas Heater and Primary Gas Heater and Mills)
- Uncontrolled release of oxygen in O₂ feedpipes to the O₂ injection points on the boiler (Secondary Gas Heater outlet duct before the Windbox) and O₂ injection nozzles on the burners.

CO₂ Capture Plant

- Uncontrolled release of flue gas (containing CO₂, CO, SO₂, SO₃, NO and NO₂) along pressurised section of the CPU
- Uncontrolled release of pure or near-pure CO₂ from downstream processing sections of the CPU
- Controlled release of flue gas from registered release points such as Pressure Safety Valves
- Controlled and uncontrolled release of Ammonia from the refrigeration plant.

The following definitions, based on AS/NZS/IEC 60079.10.1:2009 (the **Standard**), have been applied in this assessment.

Hazardous Area (on account of a toxic gas atmosphere) – is an area in which a toxic gas atmosphere is or may be expected to be present, in quantities such as to require special precautions for construction, installation and use of equipment.

Non-hazardous area NH (on account of a toxic gas atmospheres) – is an area in which a toxic gas atmosphere is not expected in quantities such as to require special precautions for the construction, installation and use of equipment.

For the purposes of evaluation, hazardous areas may be divided into three zones as follows:

Zone 0 – an area in which a toxic gas atmosphere is present continuously or for long periods or frequency.

Zone 1 - an area in which a toxic gas atmosphere is likely to occur in normal operation occasionally.

Zone 2 - an area in which a toxic gas atmosphere is not likely to occur in normal operation, but if it does occur, it will exist for a short period only.

Toxicity of constituents of flue gas, hydrogen, ammonia and Carbon Dioxide has been assessed according to the following Short Term Exposure (STEL) and Explosion Limit levels, and Oxygen against a standard enrichment level of 23 mol.% (Table 4).

Table 4 – Summary of Short Term Exposure Limit (STEL) for toxic substances and Lower Explosion Limit (LEL) for explosive substances and limits for Oxygen

	OSHA STEL (PPM)	Australian MSDS STEL (PPM)	LEL (ppm)	UEL (ppm)
CO ₂	5,000	30,000		
CO	50			
NO	25	35		
NO ₂	5			
SO ₂	5	5		
SO ₃	0.28			
NH ₃		35	148,000 (14.8 %)	250,000 (25 %)
H ₂			40,000	
Oxygen (O ₂):				
Health risk: O ₂ < 19 mol. %				
Oxidation risk O ₂ > 23 mol. %				

The assessments made were based on the definitions given above and on the calculation methodologies given in Annex A and Annex B of AS/NZS/IEC 60079.10.1:2009 (Standard). The assessment process has involved the following steps:

- Review plant design data (PIDs, PFDs etc) and identify credible release points.
- Select a certain size of leak at each credible release point (e.g. around the circumference of a flange/gasket pipe section), and calculate the theoretical release rate considering whether the flow is choked or un-choked flow, temperature and pressure, and concentration.
- Determine local conditions (ambient temperature, ventilated or enclosed), and select a Safety Factor according to the Standard.
- Determine theoretical concentration within the affected envelope.
- Compare the concentration with the STEL, Explosion limit or other selected criteria (SAFE or UNSAFE).
- If the leak is deemed UNSAFE, establish appropriate strategies and controls

For the Oxyfuel boiler the main areas of concern include the Recycled Flue Gas ductwork and pulverising mills which are slightly pressurised (3 kPa(G) at the Gas Recirculation Fan outlet down to 0.3 kPa(G) at the mill and windbox inlets), and the furnace bottom dip-seal. The modelling results have indicated that these areas could be classified as Zone 2 areas requiring additional controls given some probability (albeit small) of a flue gas leak. The main constituents with the potential to exceed STEL levels in the event of a gas leak are CO₂ and NO₂.

No areas of significant concern were identified for the ASU plant.

The main areas of concern for the CPU are in the high pressure section downstream of the flue gas compressor, in particular the Flue Gas compressor itself because this item of plant is housed within an acoustic enclosure, and around several large pressure safety valves downstream of the flue gas compressor. The modelling results have indicated that these areas could be classified as Zone 2 areas requiring additional controls given some probability (albeit small) of a flue gas or CO₂ rich flue gas leak. The main constituents with the potential to exceed STEL levels in the event of a gas leak are CO₂ and NO₂.

Based on the hazard assessment work, a number of safeguards have been implemented to assure the health and safety in the workplace:

- Operators do plant walk-downs every shift.
- Two large ventilation fans and Fixed CO₂ detectors have been installed in the CPU compressor house (3 measurement points) as well as inside the Process and Air Liquide R&D Modins (used for process control and monitoring gas quality).
- Personal CO₂ monitors must be worn around boiler in oxy-firing mode.
- Personal O₂ monitors must be worn around the ASU plant
- Personal CO₂ and NO₂ monitors must be worn in CPU plant area.

The Project also has a number of portable multi gas analysers to check levels of CO and SO₂ in addition to NO₂ and CO₂ as required.

During commissioning and subsequent operations, some leaks have occurred due to material failures on old boiler heat recovery sections (e.g., Secondary Air/Gas Heater); which have been repaired. In these cases, the personal gas monitors were very effective in picking up the leaks and as a tool to establish the extent of the area affected to be barricaded off until the plant could be shutdown and repair work undertaken. Actual measurements of gas concentrations due to leaks within an affected zone have correlated quite well with concentrations as predicted using the AS/NZS/IEC 60079.10.1:2009 modelling approach.

5. COMMISSIONING & OPERATIONAL EXPERIENCE

5.1 Air Separation Units

The Air Separation Units (commissioned in 2011) were essentially in full production by March 2012, which then allowed hot commissioning of the boiler in oxy-mode to begin.

The Air Separation Units were commissioned with the assistance of Air Liquide personnel and specialist input from Siemens for the large air compressors.

There were two main learnings from the Commissioning of the ASUs. Firstly, the importance of having specialist input and specialist training; and secondly, the sensitivity and critical nature of the hydrocarbon analysers that measure dissolved methane and other hydrocarbons on line (required as a critical safety element).

It may also be noted that training and transitioning an operations team predominantly experienced with boiler operation to Air Separation Unit operation, is a major step.

5.2 Oxyfuel Boiler

5.2.1 Commissioning Targets

As previously noted, the original Callide A Unit No. 4 boiler was refurbished and also retrofitted with the equipment necessary for Oxyfuel operation. The boiler was commissioned in air-firing mode in 2011 but was not commissioned in oxy-mode until early 2012 when the ASUs came on stream.

In summary, the key features of the Oxyfiring system are as follows:

1. The boiler has two operation/combustion modes; Air-mode and Oxy-mode
 - Air mode - Coal is burned with air (as normal)
 - Oxy mode - Coal is burned with the mixed gases of 98% pure oxygen produced with ASU and RFG (recirculated flue gas) instead of air.
2. Normal start and stop operation is conducted in Air mode only
3. Overall plant operating targets are as follows:
 - Ramp rate in Oxy mode 1% / minute (nominal)
 - Minimum load (Turndown) in Oxy mode 80%
 - Mode change time (Air mode to Oxy mode) < 90 minutes
 - Mode change time (Oxy mode to Air mode) < 90 minutes
4. Mode change can be conducted between 80%MCR and 100%MCR – No requirement for Oxy mode start/stop or low load.

The operating targets above have been achieved including operation of the boiler in oxy mode at 55% load factor.

5.2.2 Power Plant Safety System

The original boiler and turbine protection within the Distributed Control System (DCS) was a Siemens Teleperm XP installed in 1998. This system was upgraded to a T3000 system (as an add-on/standalone system) in 2008 and was subsequently assessed and verified for compliance with Queensland Legislation in accordance with AS/IEC/EN 61508 and AS/IEC/EN 61511 Standards utilising Hazard Operability (HAZOP) studies, Safety Integrity Level (SIL) studies, independent Functional Safety Assessment (FSA).

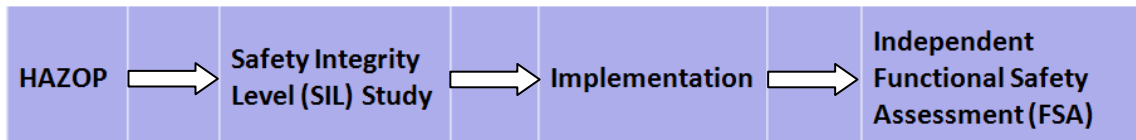

The SIL study identified 23 Safety Instrumented Functions (SIFs) for the Boiler:

- Air-firing 13 x SIL 1 and 5 x SIL 2
- Oxy-firing – 15 x SIL 1 and 3 x SIL 2

The standalone system was chosen initially for its lower cost given the relatively short demonstration life intended for the Callide Oxyfuel Project; but in consequence, this resulted in a more complex system due to replication between boiler control and protection logic which took a lot of effort to tidy up during commissioning.

5.2.3 Mode Change Results

The process of changing from air-firing (air-mode) to oxy-firing (oxy-mode) involves 3 main steps.

In air-mode, the first step is to introduce additional oxygen into the windbox. In the second step, the air inlet damper is progressively closed in whilst the flue gas recirculation damper is progressively opened. In the final step, the combustion O₂ level is brought back to normal levels 2.5 – 3.5% excess O₂ depending on the load.

Table 5 below summarises the changes in flue gas composition as the mode change is implemented.

A key outcome from this work has been to demonstrate that the combustion conditions in the boiler (primarily Adiabatic Flame Temperature and Furnace Heat Adsorption) in air-mode can be matched in oxy-mode utilising the process described above.

5.2.4 Process Optimisation

In the final stages of commissioning of the Oxyfuel boiler, attention was given to determining the optimum set points for several key variables: balance between primary gas and secondary gas to ensure good burner stability; minimisation of air ingress by mechanical improvements around some parts of the older boiler sections, and tuning of the O₂ mixing valve which controls the flow of O₂ from the ASUs into the Secondary Air/Gas duct to the boiler windbox.

Table 5 – Oxy-firing Mode Change Sequence – Flue Gas composition (indicative data)**Actual data (at 28 MWe)**

Flue Gas Composition		Air-Firing mode	O2 Sequence	RFG Mode	Oxy-mode
O2	vol%, dry	4.5	6.0	6.8	5.4
CO2	vol%, dry	15.0	16.2	59.9	72.2
CO	ppm, dry	20	20	12	12
SO2	ppm, dry	220	230	800	890
NO	ppm, dry	550	720	1195	965
NO2	ppm, dry	9	10	45	46
H2O	vol%	8	8.5	20.5	21.6
NOx	ppm, dry @ 7% O2	474	681	1223	907
NOx	ppm, dry @ 12% CO2	447	541	248	168
Flue Gas to Stack	kg/s (wet)	54	59	15.4	14.0
	Nm3/s (wet)	40.8	44.3	9.77	8.48
NOx	g/s	43	61	21	15

5.2.5 Operational Outcomes*General*

In December 2012, a series of trials were conducted with a number of coals at Callide A Power Station in order to assess their performance compared to Callide Coal under oxy-combustion conditions (Table 6).

Table 6 – Analysis of Coals from December 2012 demonstration tests

Coal		CL	CL + BL	CL + MN	MN
Description		Callide	Callide (75%) + Semi Anthracite (25%)	Callide (75%) + Med Vol. Bituminous (25%)	Medium Vol. Bit.
Total Moisture	%, as-received	12.2 - 14.1	11.5 - 12.7	11.8 - 12.5	5.8
Ash	%, as-received	22.2 - 25.6	18.9 - 20.8	24.8 - 23.7	23.9
Volatile Matter (VM)	%, as-received	20.4 - 21.9	17.2 - 18.6	21.6 - 21.9	27.9
Fixed Carbon (FC)	%, as-received	38.9 - 43.1	49.3 - 51.0	41.8 - 41.9	42.4
Fuel Ratio (FC/VM)		1.84 - 1.99	2.74 - 2.86	1.91 - 1.93	1.52
Total Sulfur	%, as-received	0.20 - 0.24	0.27 - 0.28	0.26	0.43
Chlorine	%, as-received	0.01 - 0.02	0.04	0.02	0.02
Gross Calorific Value	MJ/kg, as-received	17.28 - 19.12	20.59 - 21.91	19.04	23.43
HGI		76 - 86	80 - 85	73 - 77	50
Carbon	%, dry ash-free	73.5 - 76.7	80.6 - 81.0	76.6 - 77.9	86.1
Hydrogen	%, dry ash-free	3.52 - 3.85	3.76 - 3.84	4.12 - 4.30	5.56
Nitrogen	%, dry ash-free	0.95 - 1.07	1.31 - 1.33	1.38 - 1.44	2.69
Sulfur	%, dry ash-free	0.31 - 0.41	0.38 - 0.42	0.41 - 0.42	0.65
Oxygen	%, dry ash-free	18.1 - 23.3	13.4 - 14.0	15.9 - 17.5	5.04

Trials were conducted over 2 to 4 days for each coal; with a minimum of 24 hours air-firing and 24 hours of oxy-firing in each case. Coals were blended on the stockpile using a front-end loader and sampled using a sampling shovel (as per AS 4264) as the coal was loaded into the dump hopper feeding the boiler bunkers. All laboratory-testing of the coals was carried out in accordance with AS 1038.

Coal burn rates were determined by carefully managing coal bunker levels and weighing the coal during coal bunkering. These data were checked against mass flow measurements of pulverised fuel (PF) streams from each mill/PC pipe to the boiler.

A typical mass balance around the boiler in oxy-mode is given in Figure 7.

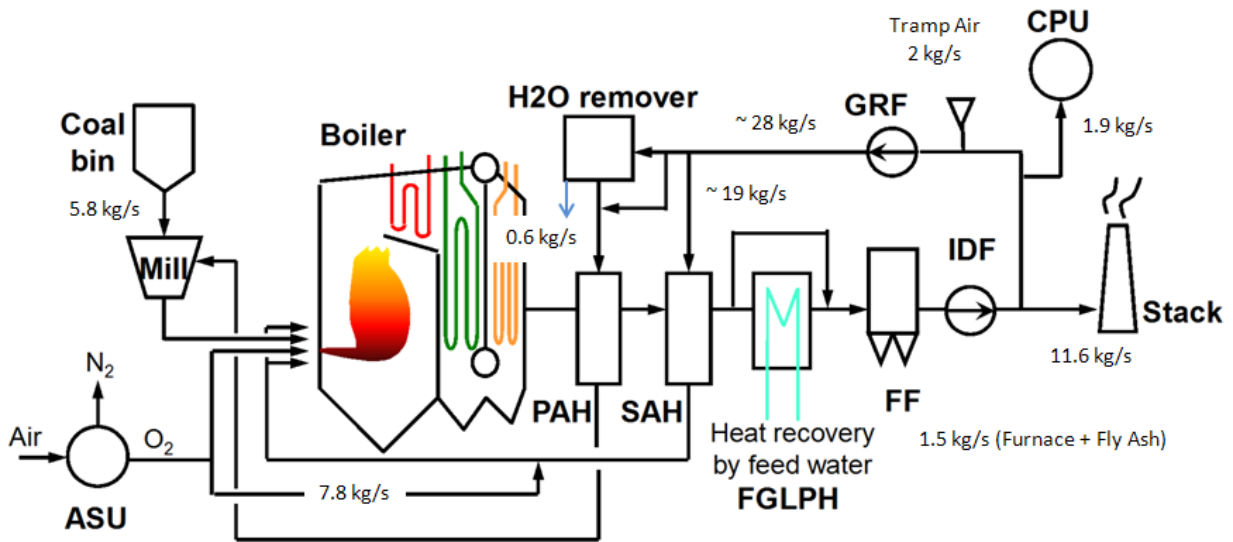

Figure 7 – Callide Oxyfuel boiler general mass balance at 30 MWe

During the combustion testing, ash samples were also taken to obtain data on the coal burn-out efficiency: furnace hopper, convection pass (or rear pass) hoppers, airheater hoppers, and fabric filter hoppers A – H inclusive. The proportion of unburned carbon was determined on each ash sample and an overall value calculated assuming (for comparison purposes) the following proportions (Table 7).

Table 7 – Ash distribution in the Callide A Unit 4 boiler

Ash sample	Furnace	Rear pass		Airheater		Fabric Filter							
		A	B	A	B	A	B	C	D	E	F	G	H
Portion by mass	15	2.5	2.5	1.25	1.25	20	16.5	12.5	10	7.5	5.5	3.5	2

Mill Performance

Mill performance was evaluated by considering the fineness of the pulverised coal product. No significant difference was observed between air-firing and oxy-firing despite the higher mill temperatures (70 °C versus 120 °C, respectively) – Table 8 and Figure 8. As expected, the PF fineness increases with an increase in HGI of the coal.

Table 8 – December 2012 Mill test results

Coal	HGI (Average)	Ash (% ar) average	Air-Firing - Mass % PF < 75 µm			Oxy-Firing - Mass % PF < 75 µm		
			A Mill	B Mill	C Mill	A Mill	B Mill	C Mill
CL	80	23.9	56.9 - 64.7	70.5 - 72.3		65.0 - 76.7		65.5 - 72.2
CL+ BL	83	19.8	69.9		66	75.9		
CL + MN	75	24.2	62.7		59.6			62.8
MN	50	23.9			55.6	51.3	49.3	

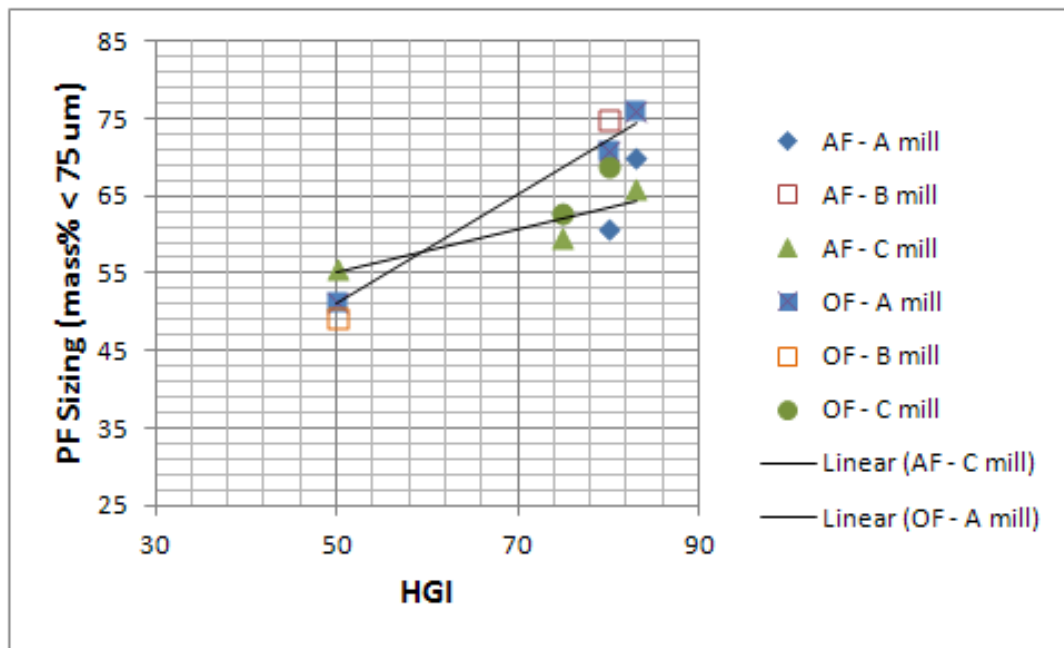

Figure 8 – December 2012 Mill test results (product fineness versus Hardgrove Grindability Index)

Combustion Efficiency

Combustion efficiency was measured in terms of unburned Carbon in Ash measured as a Loss-on-Ignition of the fly ash. Noting that the typical proportioning of ash from the boiler is 10% to 25% furnace (or bottom ash) and 75% to 90% fly ash, the following observations were made, as shown graphically in Figure 9:

- Oxy-firing conditions yield significantly lower carbon in ash levels overall compared to air-firing.
- In Oxy-firing mode, the unburned carbon in the furnace ash is about the same level as in the fly ash; usually it is much higher than in the fly ash.
- CO levels are slightly lower under Callide coal oxy-firing conditions compared to air-firing conditions under certain conditions, such as mill combination. However, theoretically there may be a competing gasification reaction of $C + CO_2 \rightarrow 2CO$ which may increase CO under oxy-firing conditions; for further investigation.

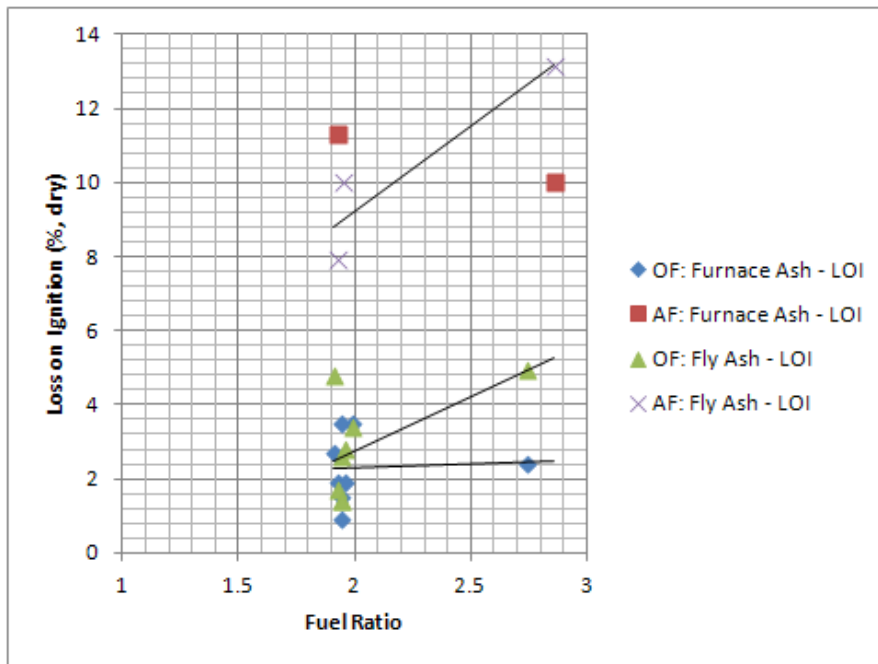

Figure 9 – Loss-on-ignition (unburnt carbon in ash) versus coal fuel ratio (Fixed Carbon/Volatile Matter)

Furnace Ash Deposition

Furnace ash deposition and slagging propensity were evaluated by observation and by utilising two calculated parameters: Temperature of Critical Viscosity (Tcv) and Slagging Index, determined from the composition of the ash as follows:

$$Tcv(^{\circ}C) = 2990 - 1470 \left(\frac{SiO_2}{Al_2O_3} \right) + 360 \left(\frac{SiO_2}{Al_2O_3} \right)^2 - 14.7(Fe_2O_3 + CaO + MgO) + 0.15(Fe_2O_3 + CaO + MgO)^2$$

$$SI = \frac{Fe_2O_3 + CaO + MgO + Na_2O + K_2O}{SiO_2 + Al_2O_3 + TiO_2}$$

Testing under air-firing and oxy-firing conditions for the different coals indicated increased furnace ash wall deposits associated with high carbon in ash and higher coal sulfur content for air- and oxy-firing conditions. Overall however, for coals with higher slagging propensity, reduced ash deposition has been observed under oxy-firing conditions (Table 9).

Table 9 – Effect of oxy-firing versus air-firing on ash deposition behaviour on combustion of coal

Coal	IDT (Red) °C	Tcv (°C)	SI	S (% ar)	Fe2O3 (% in Ash)	UBC (%)		Slagging Observations
						Air-Fir.	Oxy-Fir.	
CL	1550 - 1600	1470 - 1600	0.1 - 0.13	0.2 - 0.24	7 - 9	5 - 7	1.4 - 2.5	No ash deposits observed
CL + BL	1390	1470 - 1500	0.14 - 0.16	0.27 - 0.28	9	12	4 - 6	Some eyebrowing in Air mode
CL + MN	1550	1450	0.12	0.26	8	8	4 - 6	Some wall deposits in Air-mode
MN	1440	1600	0.1	0.43	5	> 12%	ND	Significant wall deposits in air mode but burner spreader had failed (Burner malfunction)

NOx Emissions

The following data on the effect of oxy-firing on NOx emissions is based on the December 2012 trials and other measurements; representing data at operating load factors ranging from 80% to 100%. In summary, the results indicate the following:

- NOx mass emission rate (in kgNOx/s) is significantly reduced under oxy-firing conditions as expected; yielding less than 50% of air-firing NOx emission rates (Figure 10).
- NOx mass emission rates increase with increased fuel N input (Figures 10 & 11).
- The ratio of NO₂ to NO formed is much higher under oxy-firing conditions compared to air-firing conditions (Figure 12).
- As indicated in Table 5, and supported by the data in Figures 10 and 12, the effect of oxy-firing is to significantly reduce NOx. This occurs because there is a significant reduction in the amount of atmospheric Nitrogen (N₂) normally associated with the comburent (O₂) and hence reduction in Thermal NOx, and because of the recycled flue gas re-burning effect in the furnace which reduces NOx back to N₂.

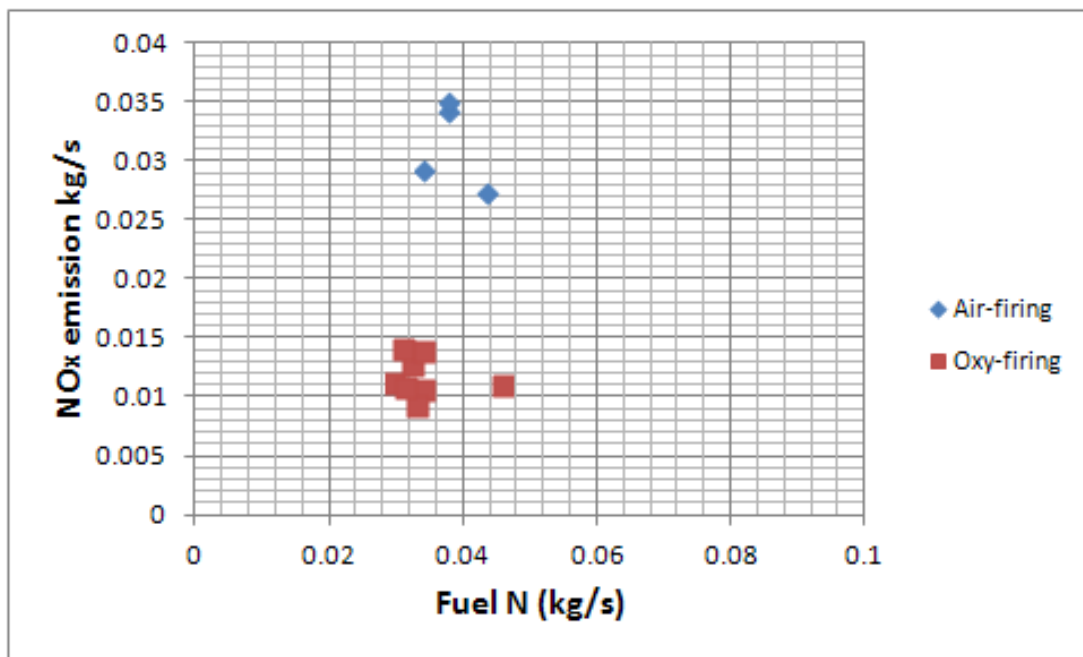

Figure 10 – NOx mass emission rate as a function of fuel nitrogen (N) input for Callide Power Station testing

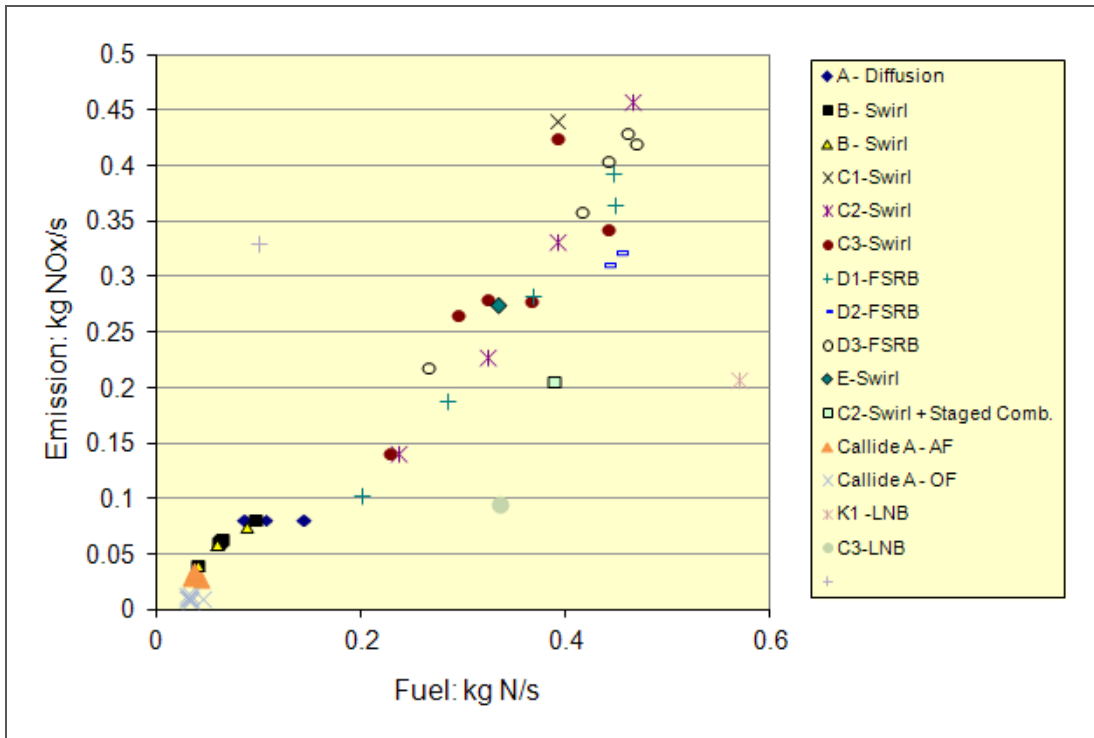

Figure 11 – NOx mass emission rate as a function of fuel (N) input for coals in Queensland Power Stations

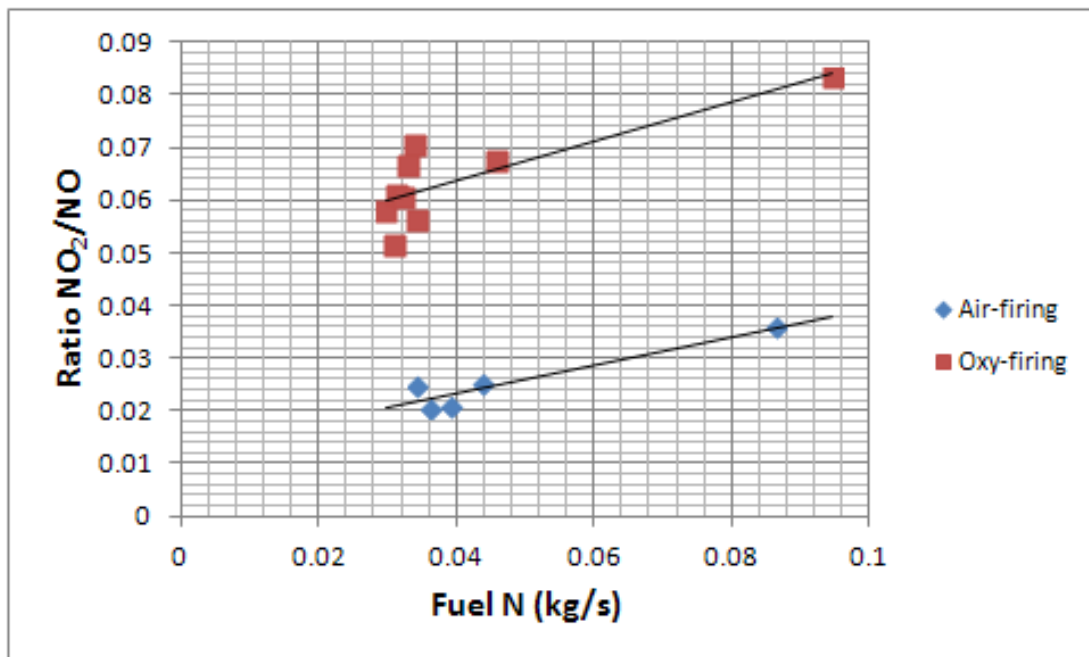

Figure 12 – Results for formation of NO₂ versus NO in conversion of Nitrogen during coal combustion (Callide A results)

SOx Emissions

The following data on SOx emissions is presented as a function of coal sulfur content measured during testing at Callide A in December 2012 at 80 % to 85% load factor. Results obtained are as follows:

- SOx emission can be represented as a power function of Sulfur in the coal (Figure 13).
- SOx levels expressed as a concentration (ppm) are 4 to 5 times higher than under air-firing conditions because there is no N₂ dilutant, as expected (Figure 13).
- There is a slightly higher absorption of SOx by fly ash under oxy-firing conditions (Figure 14). According to a mass balance, the mass emission rate of SOx from oxy-firing will be about the same or slightly less than in the air-firing case.
- SO₃ levels, measured for a limited data set) indicate:
 - Air-firing < 1 mg/Nm³ (< 1% of total SOx)
 - Oxy-firing yielded 30 – 60 mg/Nm³ (1 – 2% of total SOx)

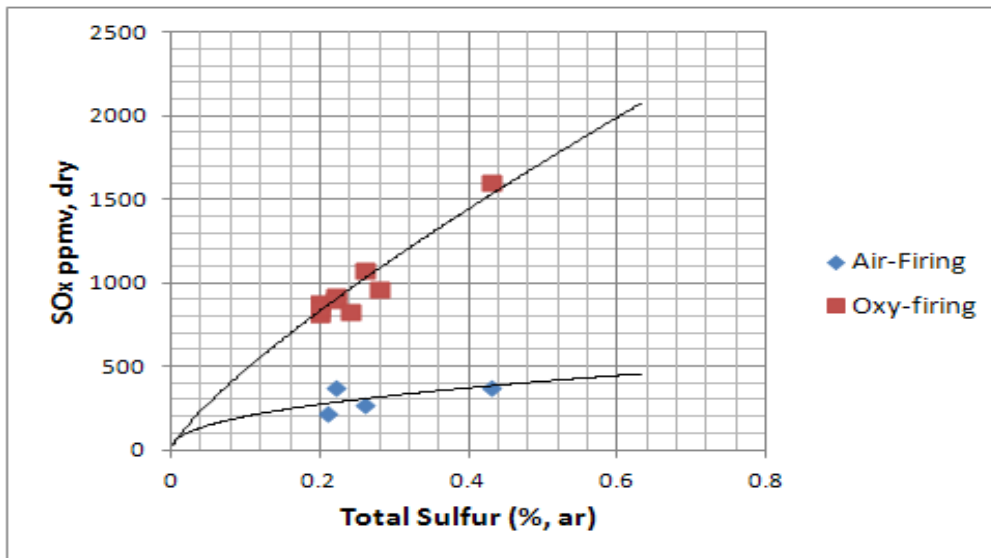

Figure 13 – SOx emissions versus Sulfur in coal air-firing versus oxy-firing

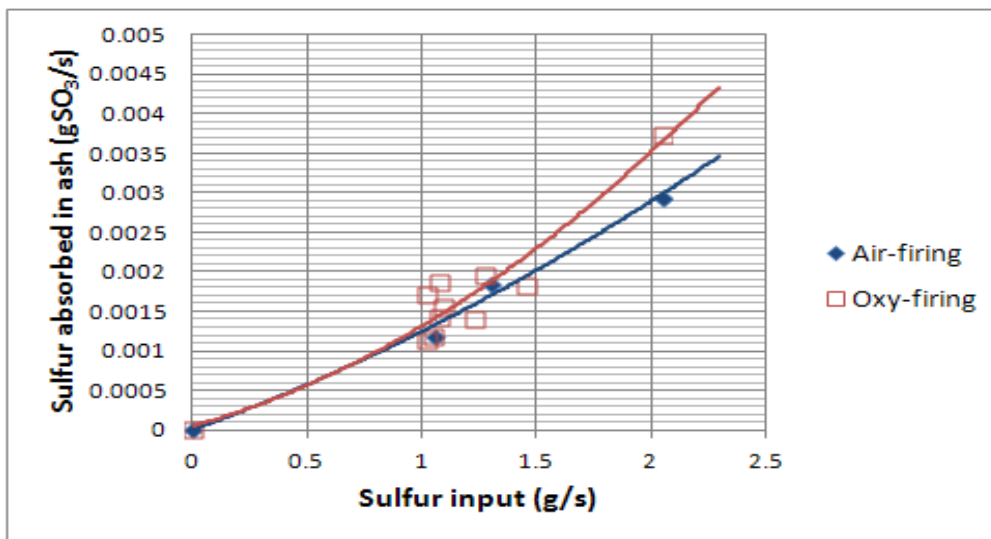

Figure 14 – Sulfur absorbed in fly ash as a function of sulfur input (air-firing versus oxy-firing)

Particulate Emissions

The Callide A facility utilises standard Fabric Filter technology to control the emissions of particulate from the boiler via the stack. Test results (Table 10), indicate the following:

- Particulate mass emission rates are slightly less in oxy-mode (assuming no flue gas to the CPU) because of the H₂O Remover spray-down of the primary gas (Figure 7).
- Additional particulate will be removed if flue gas is sent to the CPU.
- Stack efflux velocity in oxy-mode is significantly less than in air mode – which will have some impact on the dispersion of gaseous emissions.
- At Callide A, because efflux velocity is so low in oxy-mode, it is difficult to measure gas flow and sample particulates iso-kinetically.

Table 10 – Callide A demonstration plant particulate emissions

Load: 28 – 30 MWe			
Stack particulate parameters		Air-mode	Oxy-mode
Particulate Concentration	mg/Nm ³ @ 12% CO ₂	60 – 80	30 – 40
CO ₂ Concentration	mol %, dry	12 – 15	67 – 72
Gas flow rate	m ³ /s @ 0 °C, 101.3 kPa(A), wet	~ 35	~ 10
Stack Efflux Velocity	m ² /s	6 – 7	2 – 2.5
Mass emission rate	g/s	2 – 2.5	1.6 – 2.3

5.3 CO₂ Capture Plant (CPU)

A general overview of the arrangement for the CO₂ Capture Plant was presented in Section 2.8 of this report. The following sections detail the results of commissioning, testing and lessons learned to date.

5.3.1 CPU – Low Pressure (LP) Section

The Low Pressure section of CPU comprises of several parts (Figure 15), as follows:

Quencher and LP Scrubber

- Utilises water sprays and caustic soda wash
- Cools the gas from 145 °C to < 40 °C
- Reduces SO_x in the Flue Gas to < 10 ppm SO_x

Blower

- Draws flue gas from the oxy-fuel boiler ID Fan outlet and compresses the gas to 110 kPa (A).

Dust Filters

- Dynamic filter is pulsed with CO₂ to keep it clean
- Dust level at the static filter outlet is < 0.02 mg/m³.

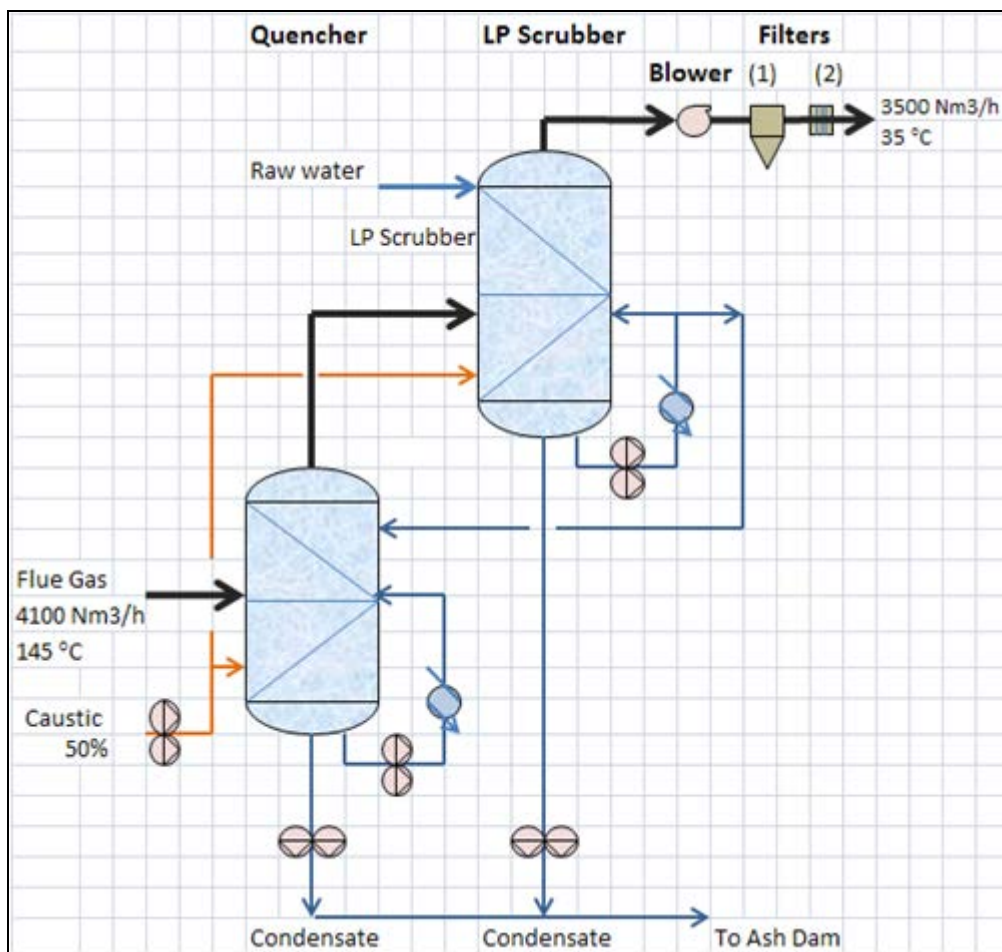

Figure 15 – CPU - Low pressure section

Considerable work was done in optimising the operation of the scrubbers in terms of Caustic Soda consumption versus final SO₂ level going to the CPU compressor. Typically the system is now controlled to a pH of around 6.5 to 6.7 whereas initially the pH operating range was 7.0 to 7.2.

In addition to process knowledge, the Project has gained important insights into the reliability and maintainability of the plant, especially the recirculation pumps which must deal with high levels of suspended solids. The flue gas blower and dust filtration equipment have proved to be very reliable and are practically maintenance free.

5.3.2 CPU – Four-Stage Centrifugal Compressor

The Centrifugal Compressor has 4 stages, and an inter-cooler and after-cooler as depicted in Figure 16. The compressor performance is optimised by reinjecting pure and impure CO₂ from downstream into the Compressor Stage 1 and Stage 3 inlets. The final product is sent to a High Pressure Scrubber at a pressure of around 2,500 kPa (A).

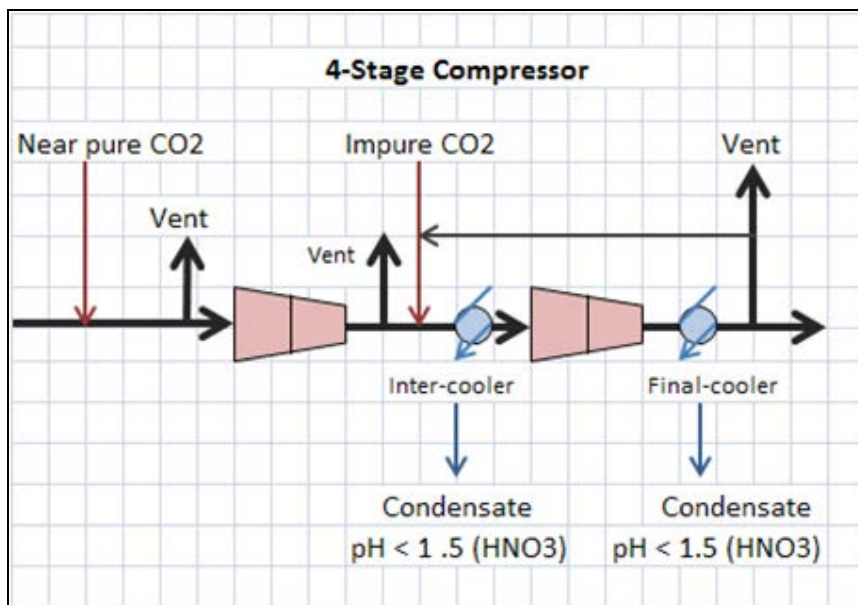

Figure 16 – CPU - Four-stage centrifugal compressor

The inter-cooler and after-cooler comprise of a shell and tube heat exchanger with the resulting condensate consisting of Nitric Acid and minor/trace products. However, whilst the detailed mechanisms of the gas behaviour in the compressor are still being investigated, the main reactions of importance to the downstream processing of the flue gas are as follows:



In the case of Nitric Acid formation, it may be noted that NO_2 is very soluble whereas NO is not. In the LP section of the CPU, the small proportion of NO_2 present in the flue gas is readily absorbed; whereas the NO escapes the caustic wash. Through the compressor, measurements of gas product and liquid product conducted by the University of Newcastle and the Callide Oxyfuel Project team indicate that around 60% of the NO is captured as Nitric Acid in the condensate streams, the balance (around 40% of the overall NO_x) passes to the HP Scrubber (predominantly as $\text{NO}_2 \sim 80\%$ and $\text{NO} \sim 20\%$).

Measurements conducted by Macquarie University at Callide A (Morrison et al, 2013) indicate that the form of Mercury in the flue gas from the Oxyfuel boiler is typically around 30 % to 40% in the elemental form (Hg^0) and 60 % to 70% in an oxidised form (Hg^{2+}). The Hg^{2+} is very soluble and readily captured in the CPU Quencher and LP Scrubber. Other data indicate that the balance of the mercury is captured as an aqueous salt in the Compressor condensate as per Equation 3 above.

The same measurements by Macquarie University indicate that virtually all other trace element species in the raw flue gas, including Halogens (Br, Cl, F, and I) and Halides (HBr, HCl, HF and HI) are effectively absorbed in the condensate stream of the Quencher and LP Scrubber vessels.

5.3.3 CPU – High Pressure (HP) Scrubber

The next section is the HP scrubber (cooler) which acts as a simple direct cooler of the flue gas from the compressor (Figure 17). A refrigeration plant provides chilled water at ~ 7 °C to the HP Scrubber. Condensate (primarily Nitric Acid) is neutralised and discharged to the ash pit.

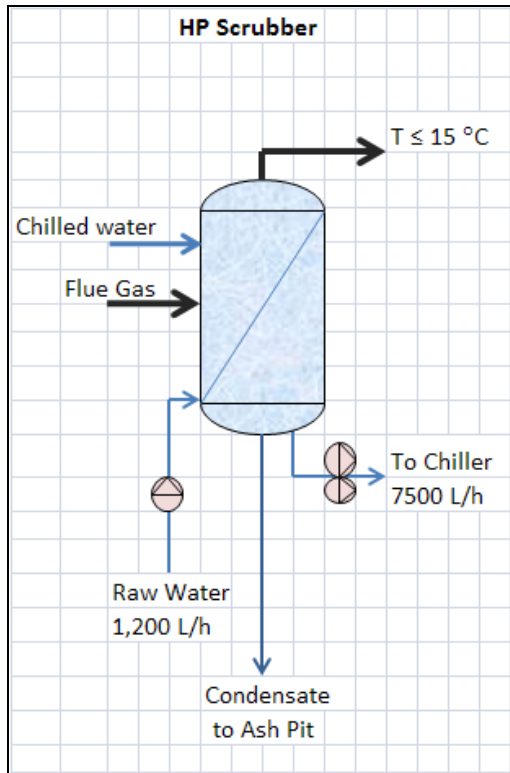

Figure 17 – CPU - High Pressure scrubber (cooler)

5.3.4 CPU – Condensate Streams

The formation and composition of the condensate streams in the CO₂ capture plant has been discussed in the preceding sections. The overall findings are summarised in Table 11 as follows.

Table 11 – CO₂ Capture Plant condensate analyses

Parameter	Unit of Meas.	Raw Water	Quencher	LP Scrubber	Compressor		HP Scrubber
					Intercooler	Final cooler	
pH		~ 7	~ 7	7.5 - 8	< 1.5	< 1.5	0.5 - 1
Total Dissolved Salts	mg/L	100 - 150	5,000 - 6,000	1,000 - 2,000	< 5	< 5	up to 1,000
Tot. Alkalinity	mg/L as CaCO ₃	< 10	1,500 - 2,000	1,000 - 1,500	< 1	< 1	< 1
Sulfate as SO ₄	mg/L	10 - 20	3,000 - 4,000	< 100 - 2,000	< 1	< 1	10 - 30
Chloride	mg/L	10	50 - 100	< 50	< 1	< 1	10 - 50
Nitrate + Nitrite as N	mg/L	ND	< 5	< 5	up to 25,000	up to 25,000	1,500 - 15,000
Mercury (Hg)	µg/L	ND	up to 15	< 0.1	20 - 50	up to 10	< 2.5

5.3.5 CPU – Dryers

The CPU has two dryers with acid-resistant adsorbent and utilises the temperature swing absorption principal for absorption and desorption (Figure 18). The purpose of the dryer is to dry the compressed/clean flue gas to very low dew point (typically minus 80 °C) and to remove any final traces of mercury.

The Dryers operate on a 12 hour cycle of adsorption and desorption respectively. The desorbed gases, together with other waste gases from the Coldbox (DeNOx and DeOx) columns, are vented from the top of the CPU coldbox.

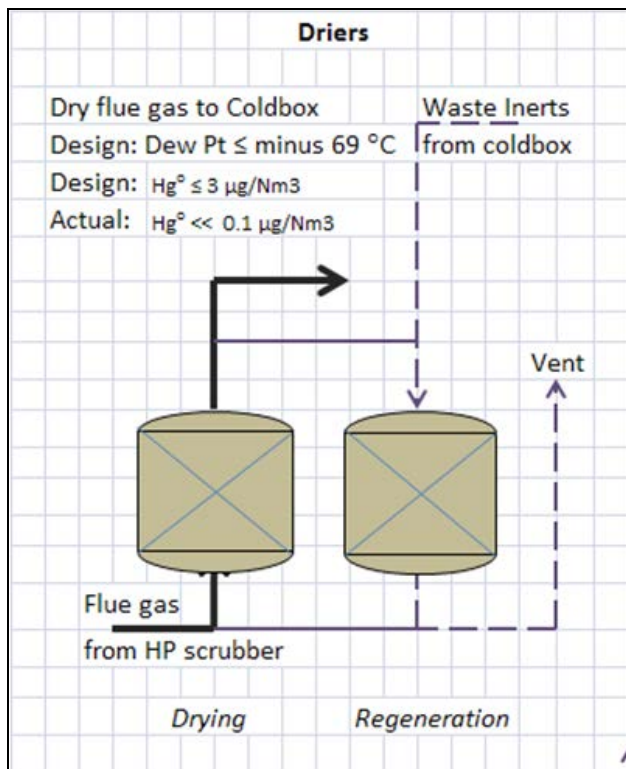

Figure 18 – CPU - Drier vessels

5.3.6 CPU Coldbox

The so-called coldbox of the CPU is used to provide further purification of the compressed, clean and now dry flue gas. Within the coldbox there is a large brazed Al heat exchanger and an array of columns and vessels as indicated in Figure 19. An O₂ set point (typically < 30 ppm) is applied to the pure gaseous CO₂ prior to sending this to the liquefier.

The CO₂ liquefier is coupled with a standard Ammonia Refrigeration plant and sits above a 100 t CO₂ storage tank. The final CO₂ product is maintained at 1450 to 2300 kPa (A) and minus 27 °C. Analysis of the product indicates purity exceeding 99.9% CO₂ (Table 12).

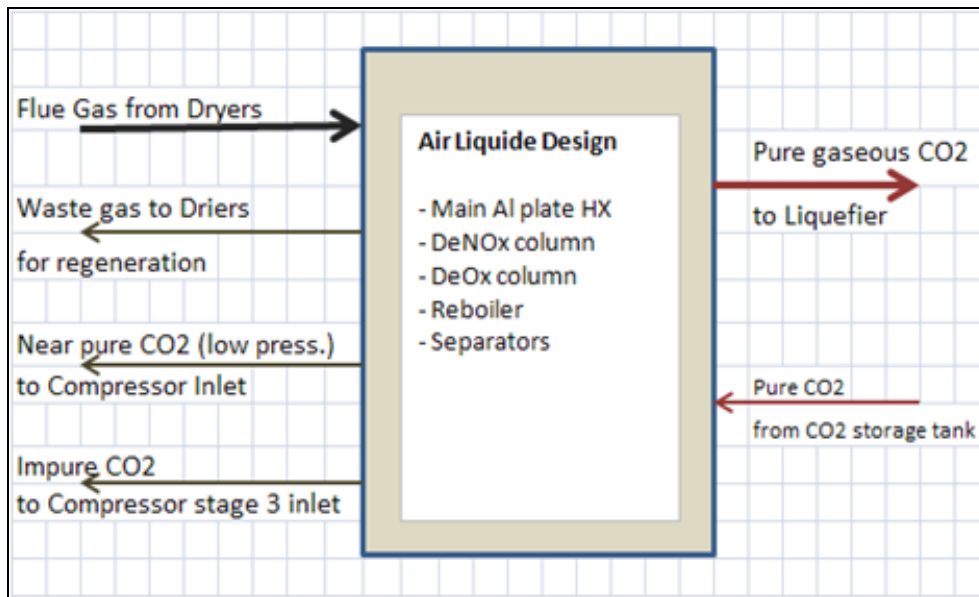

Figure 19 – CPU Coldbox

Table 12 – CPU – Process gas quality (indicative)

Gas composition	Unit of Measure	CPU – LP Section Inlet	CPU – LP Section Outlet	Product CO ₂
Boiler Load	%	80 – 100%		
H ₂ O	mol. %	19 – 22	5 – 7	< 20 ppmv
O ₂	mol. %	3 – 5	3.5 – 6	< 30 ppmv
CO ₂	mol. %	50 – 57	58 – 70	>99.95
CO	ppmv	20 - > 200	25 - > 200	< 10
NO	ppmv	500 – 1000	580 – 1250	< 2.5
NO ₂	ppmv	20 – 40	Nil	< 2.5
SO ₂	ppmv	800 – 1500	< 10	< 0.1
SO ₃	ppmv	1- 15	< 0.1	
N ₂ (+ Ar)	mol. %	Balance	Balance	Trace
Hg	ppbv	0.3 – 0.5	0.04 – 0.1	< 0.0002
	µg/Nm ³	2.7- 4.9	0.4 – 0.9	< 0.002
Particulates	mg/Nm ³ (at 60 – 70% CO ₂)	150 – 250	< 0.02	Nil
	mg/Nm ³ (at 12% CO ₂)	20 - 50	< 0.01	Nil

6. REVIEW OF PROJECT MILESTONES AND OUTCOMES

6.1 General

The Callide Oxyfuel Project had its inception as an idea in November 2003 initiated through a COAL21 Forum in Canberra with representation from major coal producers, electric utilities, State and Commonwealth Governments and research organisations. From this point, the project evolved and went through a fairly standard process of feasibility assessment, Front End Engineering Design (FEED) and Financial Investment Decision (FID).

The original project budget when the Project was officially opened in 2008 was \$210 million dollars including capital and operations and maintenance. This was later increased to \$240 million in December 2012 with support from the Commonwealth Government, COAL21 and the Japanese participants to allow for an extended operation until December 2014.

Unfortunately, whilst good budget control was maintained throughout the construction phase, the construction schedule originally proposed was not achieved and practical completion milestones were delayed by several months. The causes of the construction delays included poor weather, shortages of skilled workers, and the consequence of budget control measures applied by some of the Contractors to the project that were triggered by shortages of skilled workers and wage increases (probably linked to significant capital investments in the gas industry and a minerals boom that occurred at the time).

Commissioning also took somewhat longer than expected to complete due to the first-of-a-kind nature of the project and the necessity to optimise plant processes (both for the boiler and CPU) to achieve the desired performance outcomes. In the later stages of commissioning and early phase of operation, a number of failures of old equipment on the Callide A plant also occurred which slowed down progress.

As at March 2014, the project was operating smoothly and efficiently and the RD&D program well advanced. Overall, the Project had achieved the following Industrial Hours:

Oxyfuel boiler	5500 hours (excludes transition time)
CO ₂ Capture Plant	2500 hours (weighted average of Low Pressure, High Pressure and Coldbox operation)

A general summary of Project key milestones and events is presented in Appendix C.

6.2 Test campaigns

The Callide Oxyfuel Project is being operated primarily as a base load plant, but with regular scheduled outages typically every 6 to 8 weeks to carry out necessary mill maintenance work and plant condition assessments.

Overlapping the normal operating cycles, a number of specific test campaigns have been completed including the following:

- Optimisation of oxyfuel boiler and CO₂ capture plant conditions (June 2012 to Feb 2013)
- Initial trial of direct injection of O₂ via O₂ lances around the burners (June 2012)

- Operation of the oxyfuel boiler with H₂O remover in bypass mode: in which case H₂O in flue gas increases from about 21 vol % to about 26 vol % (tested for 3 weeks in October 2012)
- Combustion and environmental testing of Callide coal and blends of Callide coal with a semi-anthracite and a medium volatile bituminous coal (Dec 2012)
- Air Liquide Passenger tests during April to June 2013, followed by plant inspection
- High temperature corrosion probes with super-critical and ultra super-critical materials have been installed and long duration trials commenced in October 2013
- In-furnace gas measurement (temperature and O₂ distribution) completed in November 2013
- Inspection of boiler internals (frequently).

It may be noted that over the operating period from April 2013 to March 2014, the Oxyfuel boiler was operated utilising Callide coal outside of the design coal range (Table 1) with respect to Ash and Gross Calorific Value. The typical Ash range has been 24 – 28% as received, and Gross Calorific Value has typically been in the range of 17.0 – 18.5 GJ/t as-received compared to an expected minimum of 18.2 GJ/t as-received. Importantly, the out of specification coal did not have any additional impact on the plant in oxy-firing mode as compared to that in air-firing mode.

In 2014, several additional test campaigns have been planned including:

- Additional trial of direct injection of O₂ via O₂ lances around burners
- More complete process mapping (mass balances)
- Effect of CO₂ concentration on CPU performance
- Additional testing with alternative coals
- Additional Oxyfuel boiler turndown tests
- Additional ANLEC R&D flue gas compression tests

The project is being supported by a number of R&D organisations including:

- Australian National Low Emissions Coal R&D (ANLEC) – Australia
 - ✓ Macquarie University
 - ✓ University of Newcastle
- National Energy Development Organization (NEDO) – Japan
- Ministry of Energy, Trade and Industry (METI) – Japan

Further collaboration with and assistance to the FutureGen 2.0 Project in the United States is also planned.

6.3 CO₂ Storage

The Callide Oxyfuel Project has carried out a number of studies related to CO₂ Storage. These works have included evaluations of CO₂ product specifications; storage potential of depleted Natural Gas fields in the Northern Denison Trough in Central Queensland; and storage potential of sandstone aquifers in the Northern and Southern Surat Basin in South East Queensland (Spero et al 2013a).

Subsequently, a detailed appraisal specifically of the CO₂ storage potential of the Surat Basin considered gazetted Tenements in the Northern Surat (EPQ 7 and 8) and Southern Surat (EPQ 10, 12 and 14) was carried out and reported by the GCCSI (Spero et al 2013b). The study concluded

that the storage potential of the 5 GHG Storage Tenements was conservatively over 900 Mt. The appraisal presented the following information:

- Description of the assessment methodology applied.
- Description of general geology of the areas.
- Characterisation and ranking of the sites in terms of Social and Environmental factors; access and infrastructure; injectivity, storage capacity, containment.
- Summary of data in appendices based on various cores and bore holes that are available in the public domain, including stratigraphic profiles, and hydrological data.

More recently, a further study (Spero & Boyd, 2014) was conducted on the environmental and social factors relevant to a large scale geological storage of CO₂, on the basis of a staged development involving:

1. Road Transport of initial smaller volumes of CO₂ from the Callide Oxyfuel CO₂ Capture facility at Callide A near Biloela in central Queensland for the purposes of an initial CO₂ injection and storage trial.
2. CO₂ pipeline transport for a nominal 1 Mt pa CO₂ over a distance of 250 km from a large producer of CO₂ such as a Coal-fired Power Station.

The report included a summary and explanation of the important properties of CO₂, including associated impurities, that impact on the health and safety aspects of CO₂ transport and storage; a technical review of road and pipeline transport technology; and an appraisal of the relevant environmental and social factors, including descriptions of the content of an Environmental Management Plan and a Health and Safety Plan for a CO₂ transport and geological storage activity.

7. COMMUNICATIONS

An important aspect of the project has been communications with stakeholders and other interested parties.

During the initial phase of the Project from inception in 2003 to the Financial Investment Decision in 2008 a significant effort went into the preparation of information memoranda, and presentations to potential investors and funders of the project. In particular, there was a great deal of liaison with the Australian Government, Japanese Government, local Government in Central Queensland (Banana Shire Council), and the Queensland Department of Environment and Heritage Protection (Environmental Protection Agency); all of which helped shape and focus the Project on the key deliverables from a broad and international perspective. In addition, dialogue and consultation with prospective Project Joint Venture partners was essential in order to define the value proposition for each party, ensure buy-in, and ensure that the terms and conditions of the funding agreements and Joint Venture Agreement etc were fair and satisfactory for all parties.

One of the key documents that formed part of the final Project Plan was the Communications Plan, of which the main activities included the following: Project website, animation, newsletters, media releases, stakeholder engagement guidelines, and communications protocols. The implementation of the Communications Plan was done through a Communications Subcommittee comprised of representation from all the project partners.

Following the Financial Investment Decision in May 2008, the various project agreements were signed, procurement and services contracts signed, and the day to day business of running a project began in earnest. During the Project Demonstration Phase, monthly reports are being issued to the Project Partners, milestone reports are being issued to the Project Funders, numerous technical presentations are given by various technical representatives from the project, and the Commonwealth Government has an open invitation to sit in and participate in the quarterly Joint Venture meetings (which they regularly do).

Another important element of the Project has been public consultation and external stakeholder liaison. This was limited to the proposed operations at Callide A and included:

- Displays at the Biloela Shopping Mall and at Trade Expos and Conferences.
- Presentations to the Queensland Government, Banana Shire Council, Biloela Enterprise and the Gladstone Regional Development Authority.
- Presentations to the World Wildlife Foundation, Probas, Rotary, University and School groups (primary and secondary), Japanese Chamber of Industry and Commerce, British High Commission, Engineers Australia and many others.
- Open days at Callide A for the general public as well as hosting site visits for local community School groups.
- Hosting of site tours to University Groups, research institutions and industry groups from all over the world.

Overall, the project has endeavoured to keep stakeholders and interested parties, including the public, well informed about the Project and its objectives; and without exception, the response to the Callide Oxyfuel Project has been overwhelmingly positive.

8. CONCLUSION

An overview of the Callide Oxyfuel Project has been presented together with a detailed technical description of the plant and a summary of the results and learnings obtained to date.

The following conclusions may be noted:

- (i) The principal driver for oxy-firing technology development has been CO₂ capture, and secondarily reduction in other flue gas emissions. These drivers have been pursued through the 30 MWe Oxyfuel Boiler and 75 tonne per day CO₂ capture plant at Callide A, commissioned in 2012.
- (ii) Oxy-firing and CO₂ capture at Callide A has demonstrated almost complete removal of all toxic gaseous emissions (such as SO_x, NO_x, particulates, and trace elements) from the flue gas stream, which are then disposed of via the waste ash/condensate streams of the process.
- (iii) In the case of NO_x, significant reduction in stack mass emission rates are observed under oxy-firing conditions due to the significant reduction in the amount of atmospheric Nitrogen (N₂) normally associated with the comburent (O₂) and hence reduction in Thermal NO_x, and because of the re-burning effect on recycled flue gas in the furnace which reduces NO_x back to N₂.
- (iv) Other benefits of oxy-firing that have been observed and measured are improved combustion efficiency measured as reduced Carbon-in-Ash, and a reduction in the tendency to produce furnace ash deposits.
- (v) The Callide Oxyfuel Project has been complex for three principal reasons:
 - a. The Project required a large capital investment and being non-commercial required funding support from the Australian and Japanese Governments and the Coal Industry through COAL21, and equity from several Companies. The negotiation of the relevant Funding, Joint Venture and Project Agreements, required many considerations and issues to be resolved.
 - b. The demonstration project was a first-of-a-kind and therefore required very careful design and carried many perceived technical risks.
 - c. It was not possible to form a cost effective single Engineer Procure Construct (EPC) contract because of the complex and perceived technically-risky nature of the Project, so all the Capital Works had to be broken down into a large number of small contracts which were managed by Callide Oxyfuel Services Pty Ltd.
- (vi) By the end of August 2013, the issues associated with running-in of new plant had been resolved, but not without a substantial effort and many learnings along the way by all concerned with design, construction, commissioning and subsequent operations and maintenance.
- (vii) All phases of the Project have provided a great deal of knowledge and experience to inform future Oxyfuel technology development. It is very important to have the background from RD&D and pilot facilities and carefully considered design; but there will always be unforeseen issues in the plant.
- (viii) Of particular note has been the learnings derived on the safety and environmental aspects of Oxyfuel combustion.

Finally, it may be noted that the Project is supporting a number of R&D initiatives that have received funding support from the Australian National Low Emissions Coal Research & Development Ltd (ANLEC), ACALET, NEDO and METI; and is collaborating with FutureGen 2.0.

9. REFERENCES

AS 1038 *Coal and Coke – Analysis and Testing – Parts 0 to 26*

AS 4264.1-2009/Amdt 1-2011 *Coal and Coke – Sampling – Coal – Sampling procedures.*

AS/NZS/IEC 60079.10.1: 2009 *Explosive Atmospheres Part 10.1 Classification of Areas – Explosive Gas Atmospheres*

AS/IEC 61508/EN *Functional Safety of Electrical/Electronic/Programmable Electronic Safety-Related Systems (Parts 0 – 7).*

AS /IEC/EN 61511 *Functional Safety – Safety Instrumented Systems for the Process Industry Sector (Parts 1 – 3).*

ASTM *Safe Use of Oxygen and Oxygen Systems: Handbook for Design, Operation and Maintenance* (2009)

Bradshaw, B. E., Spencer, L. K., Lahtinen, A. L., Khider, K., Ryan, D. J., Colwell, J. B., Chirinos, A., Bradshaw, J., Draper, J. J., Hodgkinson, J. And McKillop, M. *An Assessment of Queensland’s CO₂ Geological Storage Prospectivity – The Queensland CO₂ Geological Storage Atlas.* Global CCS Institute, August 2010. 10 pp.

Spero, C. And Boyd, C. *Callide Oxyfuel Project – CO₂ Storage Demonstration – Surat Basin CO₂ Storage Site Selection: Part 2 – Review of Environmental and Social Factors,* Global CCS Institute 2014. 70 pp.

Spero, C., Marmin, N. And Hurter, S. *Callide Oxyfuel Project – CO₂ Storage Demonstration: Storage Options Scoping Study ,* Global CCS Institute 2013. 47 pp.

Spero, C., Marmin, N., Hurther, S., Thompson, S. And Thompson D. *Callide Oxyfuel Project – CO₂ Storage Demonstration – Surat Basin CO₂ Storage Site Selection: Part 1 – Review of Surat Basin CO₂ Storage Options.* Global CCS Institute, August 2013. 38 pp.

<http://www.globalccsinstitute.com/publications/callide-oxyfuel-project-surate-basin-co2-storage-site-selection-part-1>

10. ACKNOWLEDGEMENT

The support of the Global CCS Institute, Callide Oxyfuel Project Partners and Funders, and ANLEC Pty Ltd is gratefully acknowledged.

Oxyfuel Project Partners



Supporting Collaborator



APPENDIX A - PROJECT AND CONTRACT MANAGEMENT STRUCTURE

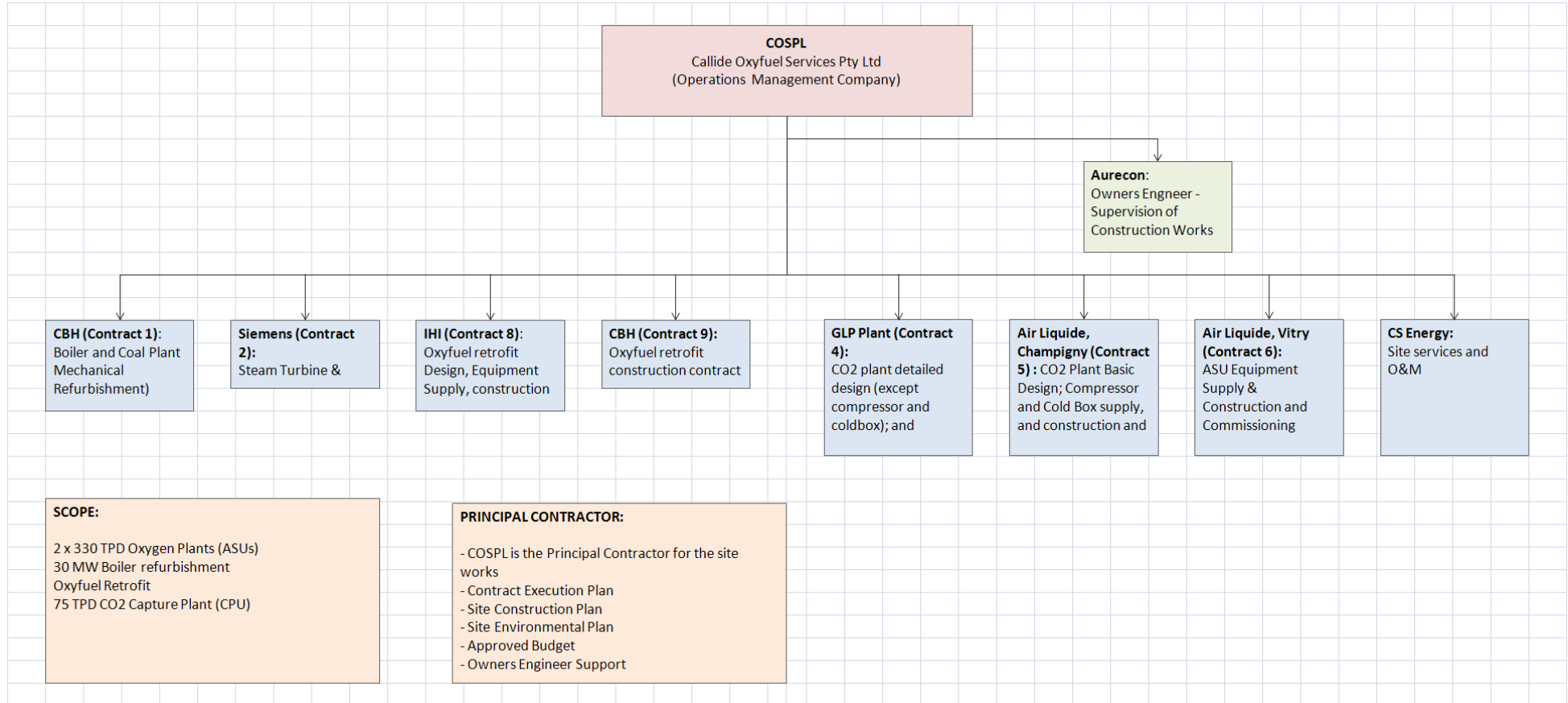

APPENDIX B - CALLIDE OXYFUEL PROJECT – PLANT PHOTOS

COP – Site Works – Oxygen and CO2 Capture Plant

CO2
capture
plant



Oxygen
plant



Heavy Lifts #1 – Boiler Primary Air Heater Lift - 27 Nov 2011

Triple Crane Lift

- Weight: 64,000kg (not incl rigging)
- Final height – 18m above ground

Cranes

- 280t Sumitomo Crawler
- 2x130t Grove All Terrain Cranes

27 Nov 2011 attempt cancelled due to high wind

Successfully completed on 29 Nov 2011.



Heavy Lifts #2 - Oxygen Plant Cold Box Column Lift – 30 Apr 2010

Dual Crane Lift

- Weight: 72,573kg (not incl rigging)
- 29.3mH x 4.8mW x 4.4mL

Cranes

- 280t Sumitomo Crawler Crane
- 130t Grove All Terrain Crane



Oxyfuel Project

Callide A - Construction

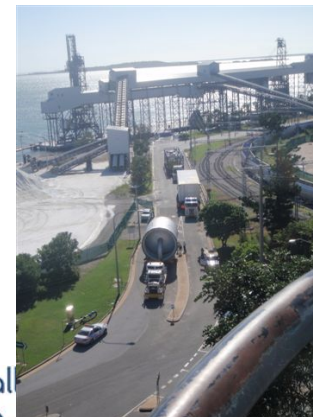

Callide
Oxyfuel Project

APPENDIX C - SUMMARY OF CALLIDE OXYFUEL PROJECT MILESTONES

Date	Project milestones achieved as at March 2014
Nov 2003	Project idea conceived
Mar 2004	Oxyfuel technology included in COAL21 National Plan of Action
Sep 2004	Japan-Australia Feasibility Study MOU signed
Oct 2006	Commonwealth Government LETDF Program - Funding Announcement
Dec 2006/Jan 2007	Oxy-firing pilot tests completed at IHI facility in Aioi, Japan (3 x 10 t coal tested)
Nov 2007	Feasibility study completed (published in April 2008)
Mar 2008	Project agreements signed
Jul 2008	Project Financial Close: Project plan & budget approved by Joint Venture
Aug 2008	Plant supply contracts awarded to IHI Engineering Australia, Air Liquide (France), GLP Plant (Melbourne), CBH and Siemens
Jan 2009	Plant refurbishment completed
Mar 2010	Site construction works begin
Mar 2011	Oxyfuel boiler construction completed
Oct 2011	Oxygen plant construction completed
Feb 2012	Commissioning in progress
Jun 2012	Practical completion of ASUs and Oxyfuel Boiler (Oxy-combustion R&D Phase commences)
Sep 2011	2nd Oxy-combustion Conference held in Yeppoon (Queensland) 2 Papers presented
Dec 2012	Practical completion of CPU 1st Major Oxyfuel test campaign completed (COSPL, IHI, University Newcastle, Macquarie University) Project launch by the Commonwealth and Japanese Governments
Apr 2013	NEDO Study on Feasibility of Large-Scale CCS in Australia undertaken by IHI in Japan and CS Energy in Australia. Study based on new super-critical oxyfuel boiler at Kogan Creek with pipeline transport and geological storage in EPQ7 (Surat Basin).
Apr - Jun 2013	Air Liquide conducts 1st Performance (Passenger) Test campaign
Jun 2013	Oxyfuel Boiler - 3600 Hours of Industrial Operation CPU - 900 Hours of Industrial Operation
Aug 2013	Callide Oxyfuel Project host plant visit and collaboration workshop with FutureGen 2.0
Sep 2013	3rd International Oxy-combustion Conference held in Ponferrada (Spain) 5 Papers presented on the Callide Oxyfuel Project
Oct 2013	IHI High Temperature Corrosion robes installed in furnace section of boiler to test ultra super-critical boiler materials
Nov 2013	In-furnace measurements conducted on Oxyfuel boiler
Mar 2014	Oxyfuel Boiler - 5500 Hours of Industrial Operation CO ₂ Capture Plant (CPU) - 2500 Hours of Industrial Operation